

New

Circulating Fluid Temperature Controller

Thermo-chiller/Rack Mount Type

Air-cooled Refrigeration

Water-cooled Refrigeration



Operable without the need to remove the unit from the rack

Front Access

Simple to control, service and maintain with all filters and drainage via the front panel

Space Saving

Multiple chillers can be mounted to a 19-inch rack.

*1 Details for 19-inch rack, refer to page 1.

310 mm

Equivalent to 7U (EIA Standards*1)



Fluid fill port

Drain port

DI filter (Option)

Particle filter (Standard)

Bypass valve (Standard)

399 mm

Equivalent to 9U (EIA Standards*1)



Cooling capacity **1.0/1.6/2.0/2.5 kW** (50 Hz)

Temperature stability **±0.1 °C**

Global power supply Single-phase **200 to 230 VAC** (50/60 Hz)



HRR Series



CAT.EUS40-66A-UK

Front Access

Maintenance

DI filter replacement

Optional Accessories [p. 21](#)



Drain pan (Built-in water leakage sensor)

Leakage sensor detects fluid leakage. Drain pan prevents leaked fluid from being leaked to the bottom of the product.

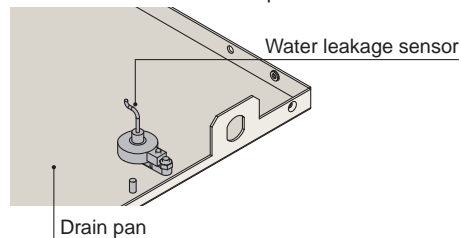

Discharge of the circulating fluid

Drain port (Rc1/4)

Cap

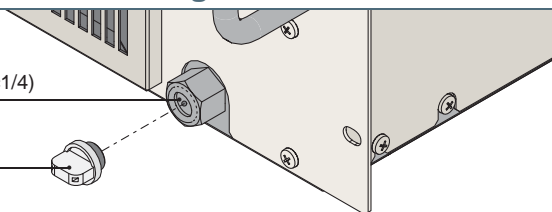

Cleaning of the dustproof filter

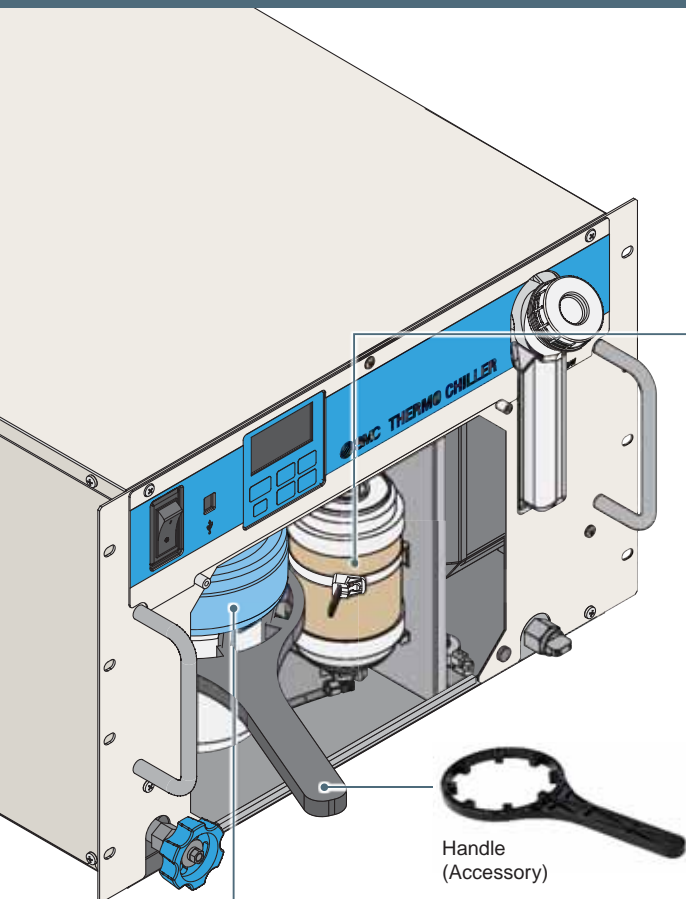
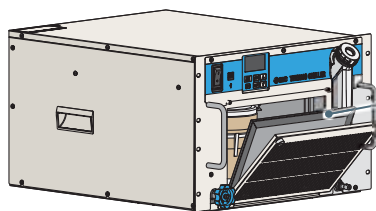

Replacement particle filter element

Optional Accessories [p. 21](#)



Space Saving

Footprint is reduced by **53 %** by installing in the 19-inch rack (EIA Standards*1).



630 mm
HRR012 x 4 units
570 mm
(Typical rack dimensions)

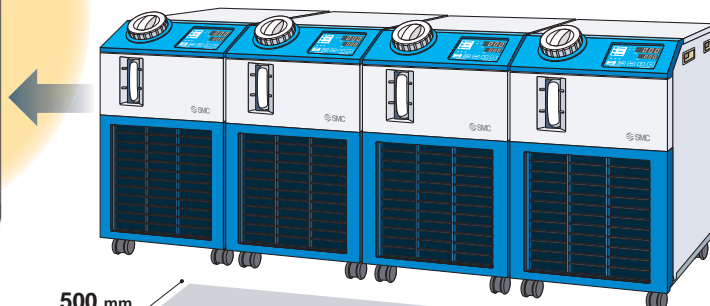

500 mm
HRS012 x 4 units
1526 mm

*1 Standards for 19-Inch Rack

Standards	EIA (Electronic Industries Alliance)
Standards no.	EIA310-D
Height	44.5 mm (=1U)
Length	450 mm (min)
Width	483.4 mm

Setting and Adjustment

Bypass valve and flow sensor are built in (standard).

Flow rate and pressure adjustment can be seen on the displayed panel.

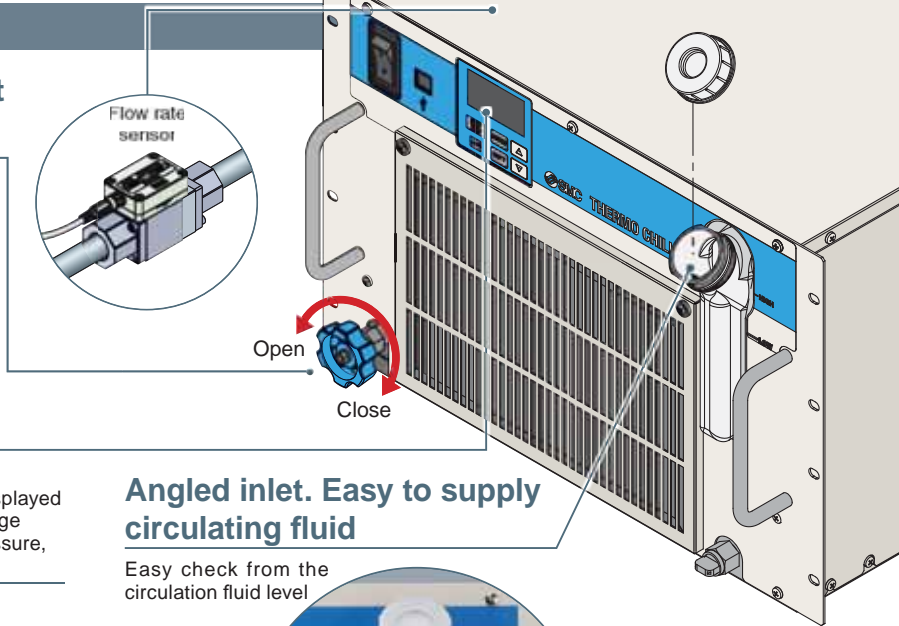

Colour LCD screen



Current value (displayed in white): Discharge temperature, pressure, flow rate, etc.

Set value (displayed in green): Set temperature, etc. is displayed.

Angled inlet. Easy to supply circulating fluid

Easy check from the circulation fluid level



Height

305 mm reduction

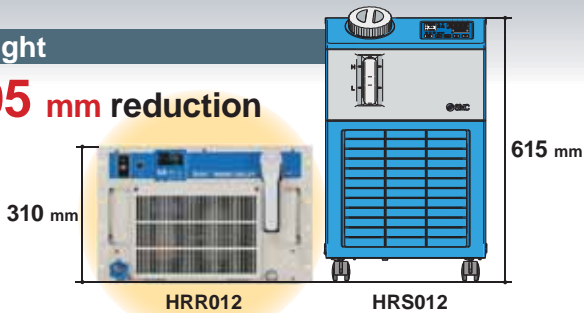

Volume

28 % reduction



Temperature stability: $\pm 0.1\text{ }^{\circ}\text{C}$

The precision temperature control method by expansion valve and temperature sensor, realized high temperature stability of $\pm 0.1\text{ }^{\circ}\text{C}$.

Air-cooled Refrigeration HRR□-A

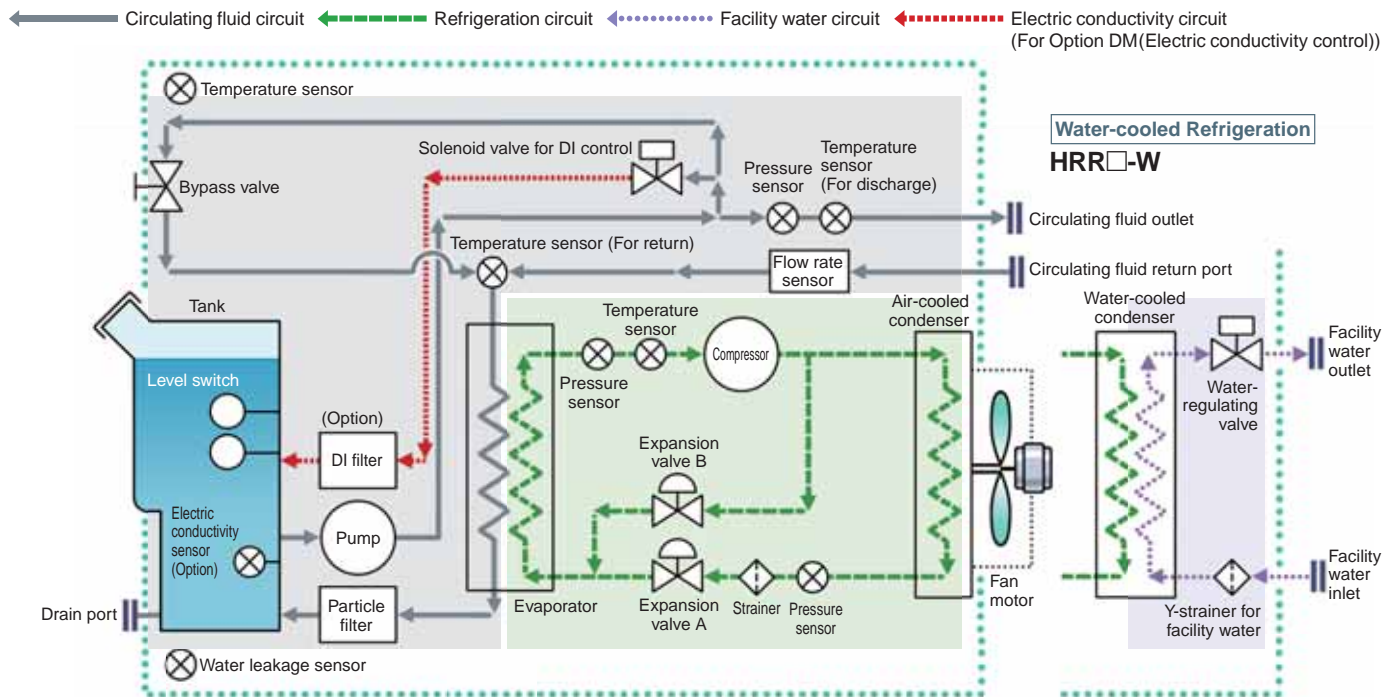

Water-cooled Refrigeration HRR□-W

Refrigeration circuit

- The compressor compresses the refrigerant gas, and discharges the high temperature and high pressure refrigerant gas.
- In the case of air-cooled refrigeration, the high temperature and high pressure refrigerant gas is cooled down by an air-cooled condenser with the ventilation of the fan, and becomes a liquid. In the case of water-cooled refrigeration, the refrigerant gas is cooled by a water-cooled condenser with the facility water in the facility water circuit, and becomes a liquid.
- The liquefied high pressure refrigerant gas expands and its temperature lowers when it passes through expansion valve A and vaporises by taking heat from the circulating fluid in the evaporator.
- The vaporised refrigerant gas is sucked into the compressor and compressed again.
- When heating the circulating fluid, the high pressure and high temperature refrigerant gas is bypassed into the evaporator by expansion valve B, to heat the circulating fluid.

Point The combination of precise control of **expansion valve A** for cooling, and **expansion valve B** for heating realised high temperature stability.

Circulating fluid circuit

- The circulating fluid discharged from the pump, is heated or cooled by the user's equipment and returns to the thermo-chiller.
- The circulating fluid is controlled to a set temperature by the refrigeration circuit, to be discharged to the user's equipment side again by the thermo-chiller.

Point

Since the refrigeration circuit is controlled by the signal from **2 temperature sensors (for return and discharge)**, precise temperature control of the circulating fluid can be performed. Therefore, there is no necessity of absorbing the temperature difference in the circulating fluid with a large tank capacity, and realises high temperature stability even with a **small-size tank**. Also, contributes to space-saving.

Facility water circuit

For water-cooled refrigeration HRR□-W

- The water-regulating valve opens and closes to keep the refrigerant gas pressure consistent. The facility water flow rate is controlled by the water-regulating valve.



Self-diagnosis function and alarm code display

Display of 23 types of alarm codes (For details → [p.16](#))

Operation is monitored all the time by the integrated sensor. The self-diagnosis result is displayed by the applicable alarm code from 23 types.

Changeable alarm set values

Setting item	Set range
Circulating fluid discharge temperature rise	10 to 45 °C
Circulating fluid discharge temperature drop	5 to 35 °C
Circulating fluid discharge pressure rise	0.05 to 0.5 MPa
Circulating fluid flow rate reduction	3.0 to 15.0 LPM



Menu for maintenance schedule

Time for periodical checks for the pumps, fan motor, dustproof filter, etc. will generate a maintenance code. Helpful for facility maintenance

Ex.) MT01 "Pump maintenance notice"

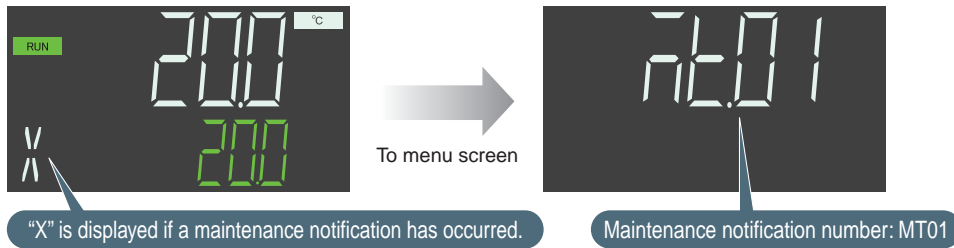

Displaying screen for operating conditions

Temperatures of the thermo-chiller, pressure, etc. can be displayed.

Displayed item
Compressor inlet temperature
Ambient temperature
Pressure of higher pressure refrigerant circuit
Pressure of lower pressure refrigerant circuit

With heating function

Heating method using discharged heat makes a heater unnecessary. Heating functions are effective to maintain a constant temperature particularly in the winter when the ambient temperature is low.

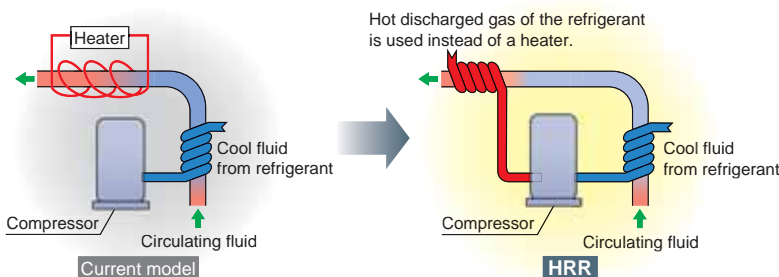

* This is just an example diagram.



Communication functions

The serial communication (RS-232C/RS-485) and contact input/output signals (2 inputs and 3 outputs) are equipped as standard. Communication with the user's equipment and system construction are possible, depending on the application.

Ex. 1 Remote signal I/O through serial communication

The remote operation is enabled (to start and stop) through serial communication.

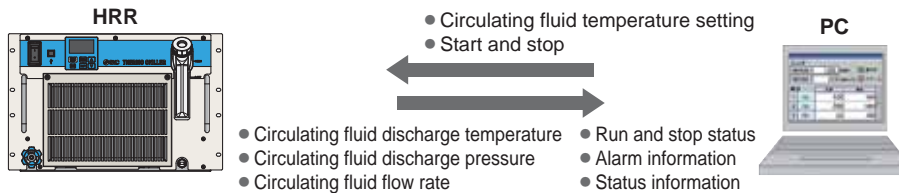

Ex. 2 Remote operation signal input

Chiller can be operated remotely by contact input signals.

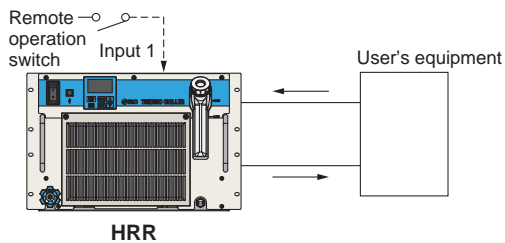

Ex. 3 Alarm and operation status (start, stop, etc.) signal output

The alarm and status generated in the product are assigned to 3 output signals based on their contents, and can be output.

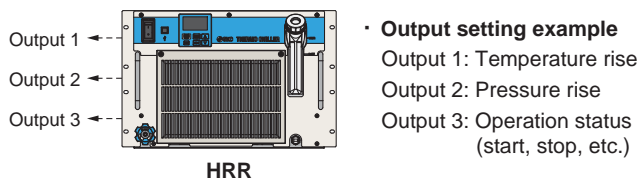



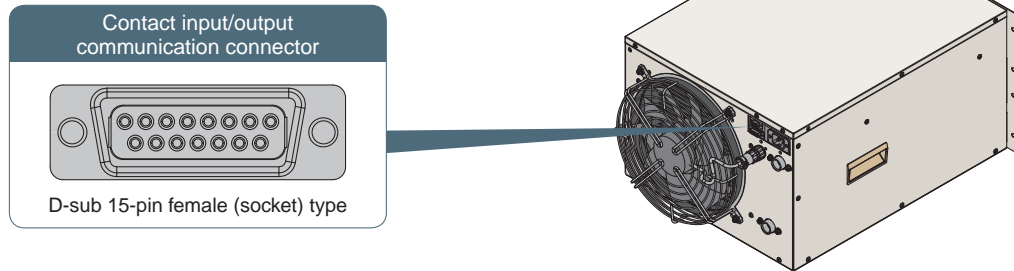

Power supply (24 VDC) available

Power can be supplied from the contact input/output communication connector to external switches, etc.

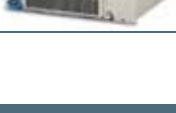

Variations

Model	Cooling capacity [W] (50/60 Hz)	Heating capacity [W] (50/60 Hz)	Cooling method	Temperature stability	Power supply	Circulating fluid	International standards
 HRR012-A/W	1000/1200	450/500	· Air-cooled refrigeration · Water-cooled refrigeration	±0.1 °C	Single-phase 200 to 230 VAC (50/60 Hz)	· Tap water · 15 % ethylene glycol aqueous solution	 (UL Standards) 
 HRR018-A/W	1600/1800						
 HRR024-A/W	2000/2400	550/700					
 HRR030-A/W	2500/3000						

Application Examples

Laser machining

Cooling of the laser irradiated part



UV curing device (Printing, painting, bonding, and sealing)

Cooling of the UV lamp

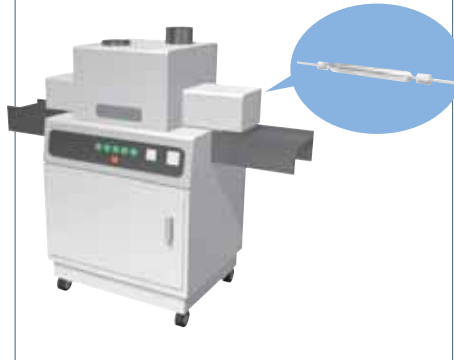

X-ray (digital) instrument

Temperature control of the X-ray tube and X-ray light sensing part

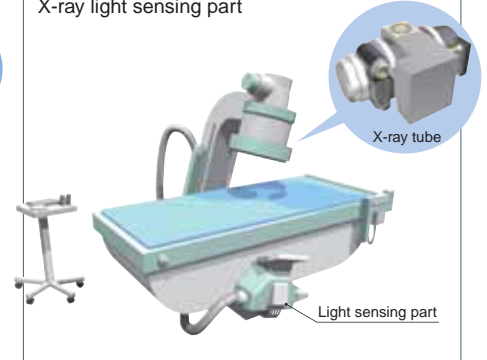

Electronic microscope

Temperature control of the electron-beam irradiated part

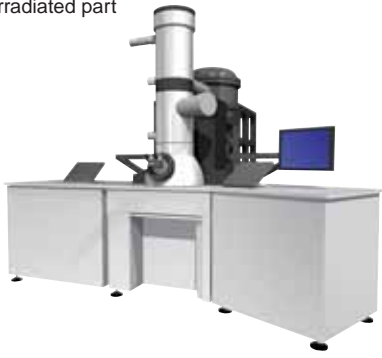

Laser marker

Cooling of the laser irradiated part

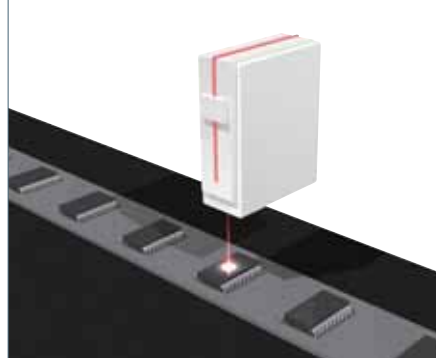

Ultrasonic wave inspection machine

Temperature control of the ultrasonic wave laser part



Laser oscillator



Laser power sensor



Transmission cable connector for fibre laser

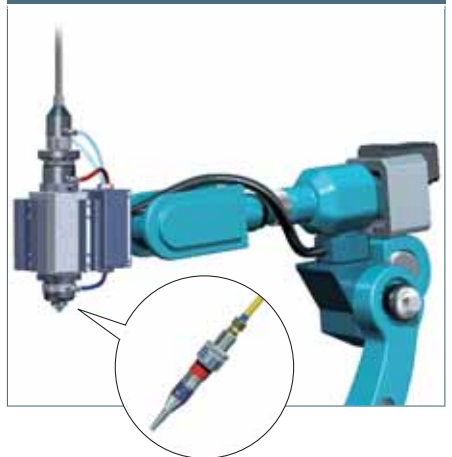

Global Supply Network

SMC has a comprehensive network in the global market.

We now have a presence of more than 500 branch offices and distributors in 83 countries and regions worldwide. With this global network, we are able to provide a global supply of our substantial range of products with the best service. We also provide full support to local factories, foreign manufacturing companies and Japanese companies in each country.



Circulating Fluid/Facility Water Line Equipment

For details, refer to the website, www.smc.eu

Pressure Switch: Monitors pressure of the circulating fluid and facility water

**3-Screen Display
High-Precision
Digital Pressure Switch**



ISE20C



ISE7□G

**Pressure Sensor for
General Fluids**



PSE56□



PSE57□

Pressure Sensor Controller



PSE200



PSE300



PSE300AC

For details, refer to the website, www.smc.eu

Fittings and Tubing

S Coupler KK



**S Coupler/Stainless Steel
(Stainless Steel 304) KKA**



Tubing T□



Metal One-touch Fittings KQB2



**Stainless Steel 316
One-touch Fittings KQG2**



Series	Material
T	Nylon
TU	Polyurethane
TH	FEP (Fluoropolymer)
TD	Modified PTFE (Soft fluoropolymer)
TL	Super PFA
TLM	PFA

Stainless Steel 316 Insert Fittings KFG2



Fluoropolymer Fittings LQ



CONTENTS

HRR Series



Thermo-chiller/Rack Mount Type HRR Series

How to Order

Air-cooled Refrigeration p. 9

Water-cooled Refrigeration p. 9

Specifications

Air-cooled Refrigeration p. 10

Water-cooled Refrigeration p. 11

Cooling Capacity p. 12

Heating Capacity p. 13

Pump Capacity p. 13

Required Facility Water Flow Rate p. 13

Dimensions

Air-cooled Refrigeration p. 14

Water-cooled Refrigeration p. 15

Operation Display Panel p. 16

Alarm p. 16

Communication Functions p. 17

● Options

With Electric Conductivity Control Function,

Applicable to DI Water Piping p. 19

Applicable to DI Water Piping p. 19

High-Pressure Pump Mounted p. 20

● Optional Accessories

① Concentration Meter p. 21

② Particle Filter Element for Replacement p. 21

③ DI Filter Replacement Cartridge p. 21

● Cooling Capacity Calculation

Required Cooling Capacity Calculation p. 22

Precautions on Cooling Capacity Calculation p. 23

Circulating Fluid Typical Physical Property Values ... p. 23

Specific Product Precautions p. 24

Thermo-chiller/ Rack Mount Type

RoHS

HRR Series



How to Order

Air-cooled Refrigeration

HRR **012** - **A** - **20** -



● **Cooling capacity**

012	1000/1200 W (50/60 Hz)
018	1600/1800 W (50/60 Hz)
024	2000/2400 W (50/60 Hz)
030	2500/3000 W (50/60 Hz)

● **Cooling method**

A	Air-cooled refrigeration
----------	--------------------------

● **Pipe thread type**

—	Rc
F	G (With Rc-G conversion fitting set)
N	NPT (With Rc-NPT conversion fitting set)

● **Option**

—	None
DM	With electric conductivity control function, Applicable to DI water piping
M	Applicable to DI water piping
T	High-pressure pump mounted
U	Conforming to UL Standards

· When multiple options are combined, indicate symbols in alphabetical order.

● **Power supply**

Single-phase 200 to 230 VAC (50/60 Hz)

Water-cooled Refrigeration

HRR **012** - **W** - **20** - **U**



● **Cooling capacity**

012	1000/1200 W (50/60 Hz)
018	1600/1800 W (50/60 Hz)
024	2000/2400 W (50/60 Hz)
030	2500/3000 W (50/60 Hz)

● **Cooling method**

W	Water-cooled refrigeration
----------	----------------------------

● **Option**

—	None
DM	With electric conductivity control function, Applicable to DI water piping
M	Applicable to DI water piping
T	High-pressure pump mounted

· When multiple options are combined, indicate symbols in alphabetical order.

● **Power supply**

Single-phase 200 to 230 VAC (50/60 Hz)

● **Pipe thread type**

—	Rc
F	G (With Rc-G conversion fitting set)
N	NPT (With Rc-NPT conversion fitting set)

Specifications: Air-cooled Refrigeration

Model	HRR012-A	HRR018-A	HRR024-A	HRR030-A					
Cooling method	Air-cooled refrigeration								
Refrigerant	R410A (HFC)								
Refrigerant charge [kg]	0.38		0.47						
Control method	PID control								
Ambient temperature/Humidity/Altitude*1, 13	Temperature: 5 to 40 °C, Humidity: 30 to 70 %, Altitude: less than 3000 m								
Circulating fluid system	Circulating fluid*2	Tap water, 15 % ethylene glycol aqueous solution							
	Set temperature range*1 [°C]	10 to 35							
	Cooling capacity (50/60 Hz)*3 [W]	1000/1200	1600/1800	2000/2400	2500/3000				
	Heating capacity (50/60 Hz)*4 [W]	450/500		550/700					
	Temperature stability*5 [°C]	±0.1							
	Pump capacity (50/60 Hz)*6 [MPa]	0.13 (at 7 l/min)/0.18 (at 7 l/min) For Option T: 0.42 (at 10 l/min)/0.4 (at 14 l/min) For Option MT: 0.32 (at 10 l/min)/0.32 (at 14 l/min)							
	Rated flow (50/60 Hz)*7 [l/min]	7/7 For Options T, MT: 10/14							
	Flow display range [l/min]	3 to 16							
	Electric conductivity display range [µS/cm]	2 to 48 (Only for Option DM)							
	Electric conductivity setting range [µS/cm]	5 to 45 (Only for Option DM)							
	Particle filter nominal filtration rating [µm]	5							
	Bypass valve	Installed							
	Tank capacity [L]	Approx. 4							
	Outlet, Return port size	Rc1/2							
	Drain port size	Rc1/4, With cap							
Leakage protection	Drain pan (With water leakage sensor)								
Fluid contact material	Stainless steel, Copper (Heat exchanger brazing)*11, Brass*16, SiC, Alumina ceramic, Carbon, PP, PE, POM, PA, FKM, EPDM, PVC, PPS, AS, Fluoropolymer*12, Ion exchange resin*12								
Electrical system	Power supply	Single-phase 200 to 230 VAC, 50/60 Hz, Allowable voltage range ±10 %*14							
	Circuit protector [A]	10 For Options T, MT: 15							
	Applicable earth leakage breaker capacity*8	Rated current: 10 A For Options T, MT: 15 A Sensitivity current: 30 mA							
	Cable quantity x Size (Including grounding cable)*15	3 cores x 14 AWG (3 cores x 2.0 mm ²)							
	Rated operating current (50/60 Hz)*3 [A]	3.6/4.0		3.6/4.3		5.2/5.8		5.5/6.2	
		For Options T, MT							
	Rated power consumption (50/60 Hz)*17 [kW(kVA)]	4.7/6.2		4.7/6.5		6.3/8.0		6.5/8.3	
For Options T, MT									
Communication function	0.6/0.8 (0.7/0.8)			0.7/0.9 (0.7/0.9)		0.9/1.2 (1.1/1.2)		1.0/1.2 (1.1/1.3)	
Noise level (50/60 Hz)*9 [dB]	59/60		59/60		61/64		61/64		
Accessories*18	Power supply connector, Particle filter element and maintenance handle, Operation manual								
Weight*10 [kg]	40		46						

*1 It should have no condensation. During seasons or in locations where the ambient temperature is likely to fall below freezing point, please contact SMC for that case.
 *2 If tap water is used, use water that conforms to Water Quality Standards of the Japan Refrigeration and Air Conditioning Industry Association (JRA GL-02-1994 cooling water system - circulating type - make-up water).
 *3 ① Ambient temperature: 25 °C, ② Circulating fluid temperature: 20 °C, ③ Circulating fluid rated flow, ④ Circulating fluid: Tap water, ⑤ Power supply: 200 VAC, ⑥ Piping length: Shortest
 For models with high-pressure pump mounted (Options T, MT), the cooling capacity will decrease by 300 W.
 *4 ① Ambient temperature: 25 °C, ② Circulating fluid temperature: 20 °C, ③ Circulating fluid rated flow, ④ Circulating fluid: Tap water, ⑤ Power supply: 200 VAC, ⑥ Piping length: Shortest
 *5 Temperature at the thermo-chiller outlet when the circulating fluid flow is rated flow, and the circulating fluid outlet and return port are directly connected. Installation environment and the power supply are within specification range and stable.
 *6 The capacity at the thermo-chiller outlet when the circulating fluid temperature is 20 °C.
 *7 Required flow rate for maintaining the cooling capacity or temperature stability
 The specification of the cooling capacity and the temperature stability may not be satisfied if the flow rate is lower than the rated flow.
 *8 Purchase an earth leakage breaker with sensitivity current of 30 mA/power supply 200 VAC separately.

*9 Front: 1 m, height: 1 m, stable with no load. Other conditions → See *3.
 *10 Weight in the dry state without circulating fluids
 The weight will increase by 1 kg when Option DM (With electric conductivity control function + Applicable to DI water piping) is selected.
 The weight will increase by 5 kg when Option T (High-pressure pump mounted) or MT (Applicable to DI water piping + High-pressure pump mounted) is selected.
 *11 Copper and brass are not included when Option M (Applicable to DI water piping) or MT (Applicable to DI water piping + High-pressure pump mounted) is selected.
 *12 For Option DM (With electric conductivity control function + Applicable to DI water piping)
 13 If the product is used at altitude of 1000 m or higher, refer to “ For altitude of 1000 m or higher” on page 25.
 *14 No continuous voltage fluctuation
 *15 To be prepared by the customer
 *16 For Option T (High-pressure pump mounted), this material is included.
 *17 ① Ambient temperature: 25 °C, ② Circulating fluid temperature: 20 °C, ③ Circulating fluid rated flow, ④ Circulating fluid: Tap water, ⑤ Power supply: 200 VAC, ⑥ Piping length: Shortest, ⑦ At the rated cooling load applied
 *18 For Option DM (With electric conductivity control function + Applicable to DI water piping), a DI filter is attached.
 For pipe thread type F, a G thread conversion fitting set is attached.
 For pipe thread type N, an NPT thread conversion fitting set is attached.

HRR Series

Specifications: Water-cooled Refrigeration

Model	HRR012-W	HRR018-W	HRR024-W	HRR030-W		
Cooling method	Water-cooled refrigeration					
Refrigerant	R410A (HFC)					
Refrigerant charge [kg]	0.25		0.40			
Control method	PID control					
Ambient temperature/Humidity/Altitude*1, 14	Temperature: 5 to 40 °C, Humidity: 30 to 70 %, Altitude: less than 3000 m					
Circulating fluid system	Circulating fluid*2	Tap water, 15 % ethylene glycol aqueous solution				
	Set temperature range*1 [°C]	10 to 35				
	Cooling capacity (50/60 Hz)*3 [W]	1000/1200	1600/1800	2000/2400	2500/3000	
	Heating capacity (50/60 Hz)*4 [W]	450/500		550/700		
	Temperature stability*5 [°C]	±0.1				
	Pump capacity (50/60 Hz)*6 [MPa]	0.13 (at 7 l/min)/0.18 (at 7 l/min) For Option T: 0.42 (at 10 l/min)/0.4 (at 14 l/min) For Option MT: 0.32 (at 10 l/min)/0.32 (at 14 l/min)				
	Rated flow (50/60 Hz)*7 [l/min]	7/7 For Options T, MT: 10/14				
	Flow display range [l/min]	3 to 16				
	Electric conductivity display range [µS/cm]	2 to 48 (Only for Option DM)				
	Electric conductivity setting range [µS/cm]	5 to 45 (Only for Option DM)				
	Particle filter nominal filtration rating [µm]	5				
	Bypass valve	Installed				
	Tank capacity [L]	Approx. 4				
	Outlet, Return port size	Rc1/2				
	Drain port size	Rc1/4, With cap				
Leakage protection	Drain pan (With water leakage sensor)					
Fluid contact material	Stainless steel, Copper (Heat exchanger brazing)*11, Brass*17, SiC, Alumina ceramic, Carbon, PP, PE, POM, PA, FKM, EPDM, PVC, PPS, AS, Fluoropolymer*12, Ion exchange resin*12					
Facility water system	Temperature range [°C]	5 to 40				
	Pressure range [MPa]	0.3 to 0.5				
	Required flow rate (50/60 Hz)*13 [l/min]	8	12	14	15	
	Inlet-outlet pressure differential of facility water [MPa]	0.3 or more				
	Port size	Rc3/8				
Fluid contact material	Stainless steel, Copper (Heat exchanger brazing), Bronze, Brass, Synthetic rubber					
Electrical system	Power supply	Single-phase 200 to 230 VAC, 50/60 Hz, Allowable voltage range ±10 %*15				
	Circuit protector [A]	10 For Options T, MT: 15				
	Applicable earth leakage breaker capacity*8	Rated current: 10 A For Options T, MT: 15 A Sensitivity current: 30 mA				
	Cable quantity x Size (Including grounding cable)*16	3 cores x 14 AWG (3 cores x 2.0 mm ²)				
	Rated operating current (50/60 Hz)*3 [A]	3.2/3.6		3.3/3.6	4.9/5.1	4.9/5.2
		For Options T, MT				
Rated power consumption (50/60 Hz)*18 [kW(kVA)]	4.3/5.8		4.4/5.8	6.0/7.3	6.0/7.4	
	For Options T, MT					
Rated power consumption (50/60 Hz)*18 [kW(kVA)]	0.6/0.7 (0.7/0.7)	0.6/0.7 (0.7/0.7)	0.8/1.0 (1.0/1.0)	0.8/1.0 (1.0/1.0)		
Communication function	Contact input/output, Serial RS-485/RS-232C					
Noise level (50/60 Hz)*9 [dB]	59/60	59/60	61/64	61/64		
Accessories*19	Power supply connector, Particle filter element and maintenance handle, Operation manual					
Weight*10 [kg]	41		45			

- *1 It should have no condensation. During seasons or in locations where the ambient temperature is likely to fall below freezing point, please contact SMC for that case.
- *2 If tap water is used, use water that conforms to Water Quality Standards of the Japan Refrigeration and Air Conditioning Industry Association (JRA GL-02-1994 cooling water system - circulating type - make-up water).
- *3 ① Facility water temperature: 25 °C, ② Circulating fluid temperature: 20 °C, ③ Circulating fluid rated flow, ④ Circulating fluid: Tap water, ⑤ Power supply: 200 VAC, ⑥ Piping length: Shortest
For models with high-pressure pump mounted (Options T, MT), the cooling capacity will decrease by 300 W.
- *4 ① Ambient temperature: 25 °C, ② Facility water temperature: 25 °C, ③ Circulating fluid temperature: 20 °C, ④ Circulating fluid rated flow, ⑤ Circulating fluid: Tap water, ⑥ Power supply: 200 VAC, ⑦ Piping length: Shortest
- *5 Temperature at the thermo-chiller outlet when the circulating fluid flow is rated flow, and the circulating fluid outlet and return port are directly connected. Installation environment and the power supply are within specification range and stable.
- *6 The capacity at the thermo-chiller outlet when the circulating fluid temperature is 20 °C.
- *7 Required flow rate for maintaining the cooling capacity or temperature stability
The specification of the cooling capacity and the temperature stability may not be satisfied if the flow rate is lower than the rated flow.
- *8 Purchase an earth leakage breaker with sensitivity current of 30 mA/ power supply 200 VAC separately.
- *9 Front: 1 m, height: 1 m, stable with no load, Other conditions → See *3.

- *10 Weight in the dry state without circulating fluids and facility water (for water-cooled refrigeration)
The weight will increase by 1 kg when Option DM (With electric conductivity control function + Applicable to DI water piping) is selected.
The weight will increase by 5 kg when Option T (High-pressure pump mounted) or MT (Applicable to DI water piping + High-pressure pump mounted) is selected.
- *11 Copper and brass are not included when Option M (Applicable to DI water piping) or MT (Applicable to DI water piping + High-pressure pump mounted) is selected.
- *12 For Option DM (With electric conductivity control function + Applicable to DI water piping)
- *13 Required flow rate when a load for the cooling capacity is applied under the conditions in *3.
- *14 If the product is used at altitude of 1000 m or higher, refer to "*" For altitude of 1000 m or higher" on page 25.
- *15 No continuous voltage fluctuation
- *16 To be prepared by the customer
- *17 For Option T (High-pressure pump mounted), this material is included.
- *18 ① Facility water temperature: 25 °C, ② Circulating fluid temperature: 20 °C, ③ Circulating fluid rated flow, ④ Circulating fluid: Tap water, ⑤ Power supply: 200 VAC, ⑥ Piping length: Shortest, ⑦ At the rated cooling load applied
- *19 For Option DM (With electric conductivity control function + Applicable to DI water piping), a DI filter is attached.
For pipe thread type F, a G thread conversion fitting set is attached.
For pipe thread type N, an NPT thread conversion fitting set is attached.

Cooling Capacity

* If the product is used at altitude of 1000 m or higher, refer to "Operating Environment/Storage Environment" (page 25) Item 14 * For altitude of 1000 m or higher.
 * For models with high-pressure pump mounted (-T, -MT), the cooling capacity will decrease by about 300 W from each graph.

HRR012-A, HRR012-W

[50 Hz]

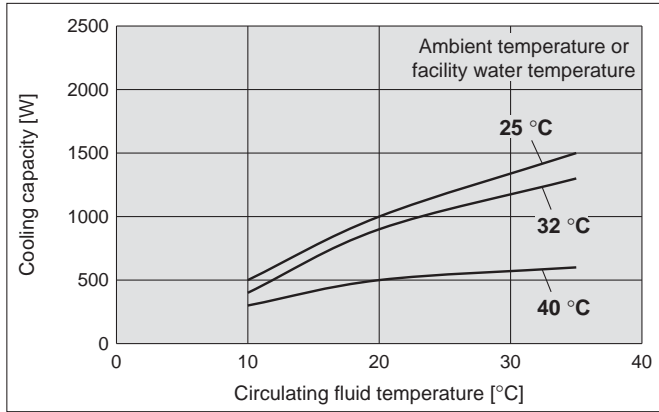

[60 Hz]

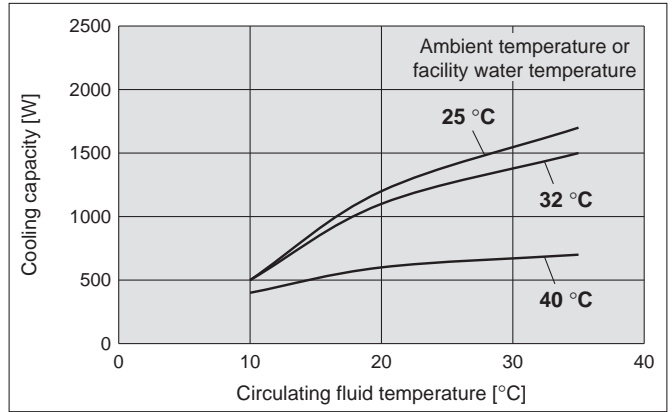

HRR018-A, HRR018-W

[50 Hz]

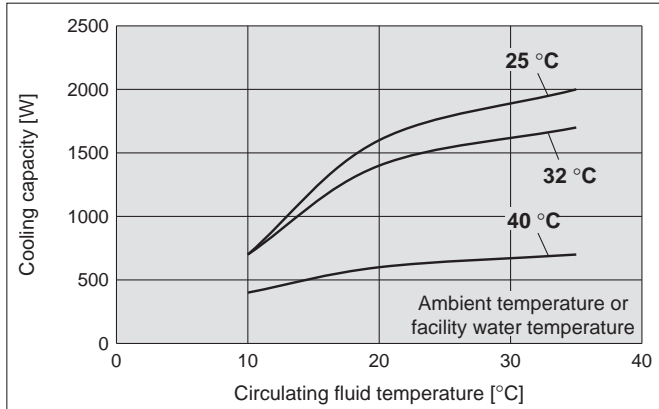

[60 Hz]

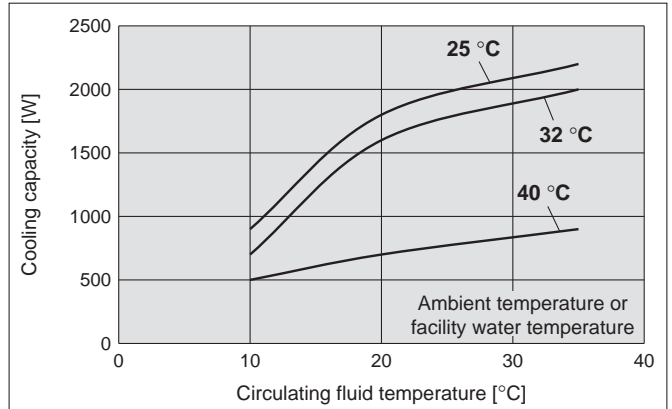

HRR024-A, HRR024-W

[50 Hz]

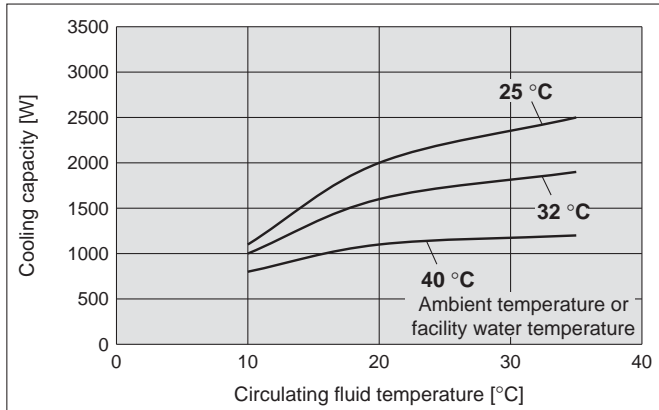

[60 Hz]

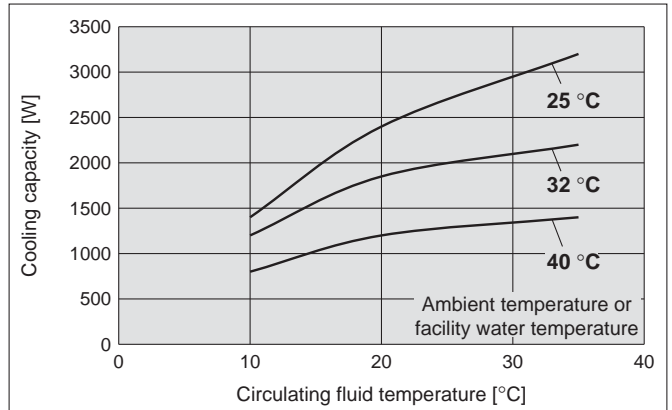

HRR030-A, HRR030-W

[50 Hz]

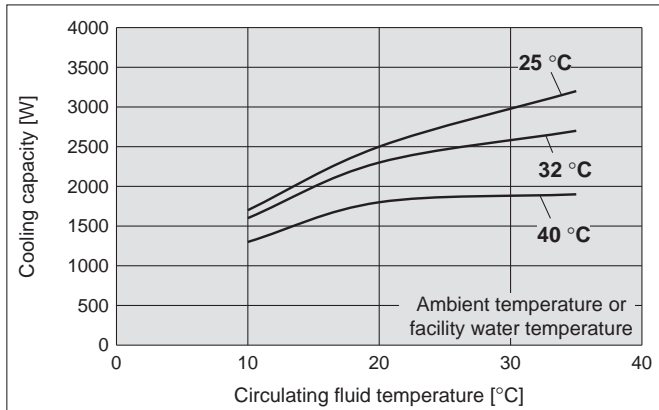

[60 Hz]

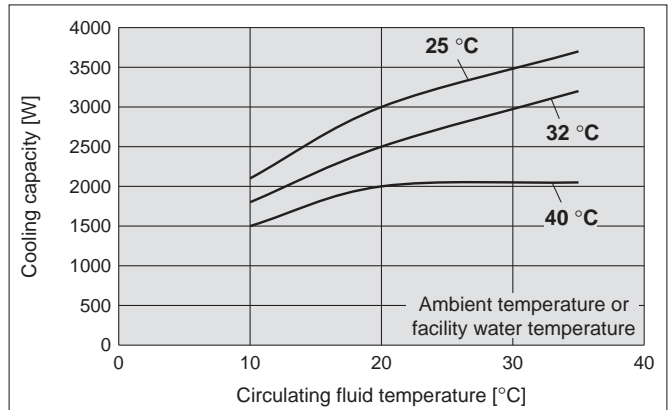

HRR Series

Heating Capacity

HRR⁰¹²₀₁₈-A, HRR⁰¹²₀₁₈-W

[50 Hz]

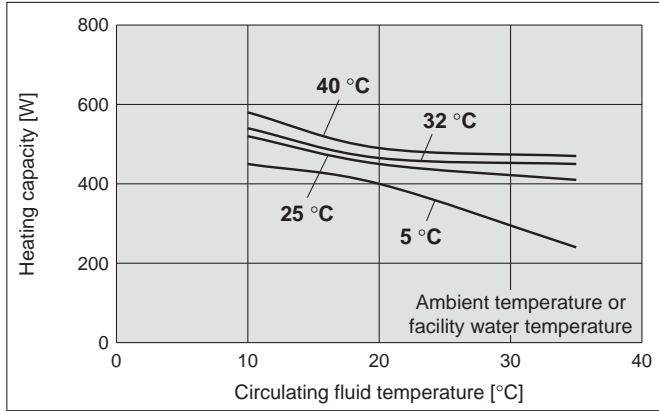

[60 Hz]

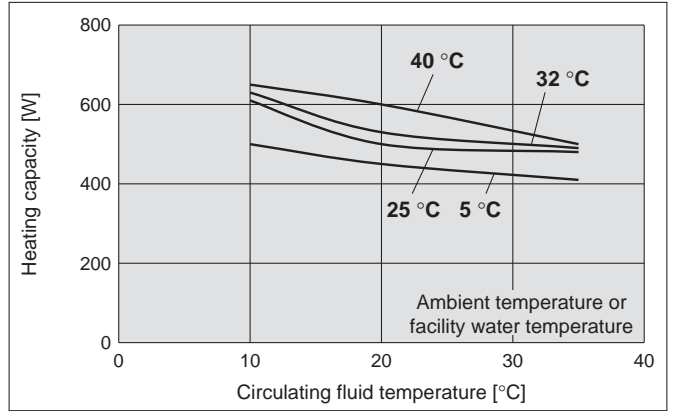

HRR⁰²⁴₀₃₀-A, HRR⁰²⁴₀₃₀-W

[50 Hz]

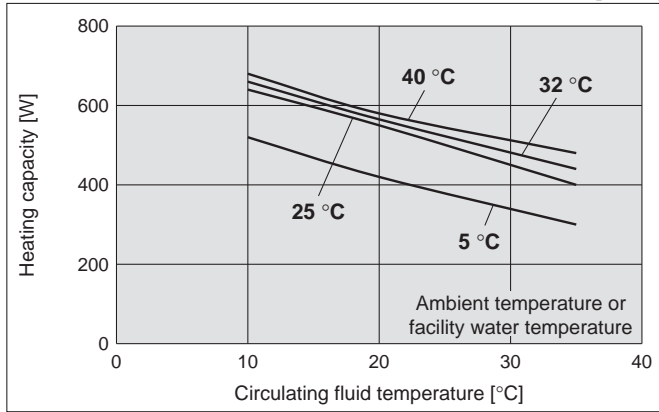

[60 Hz]

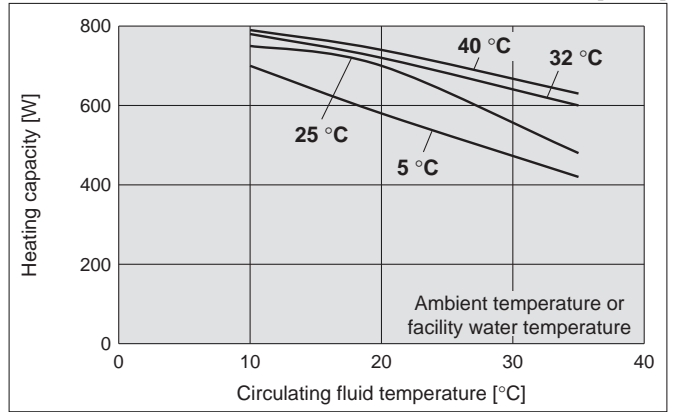

Pump Capacity

HRR⁰¹²₀₁₈-A, HRR⁰¹²₀₁₈-W
HRR⁰²⁴₀₃₀-A, HRR⁰²⁴₀₃₀-W

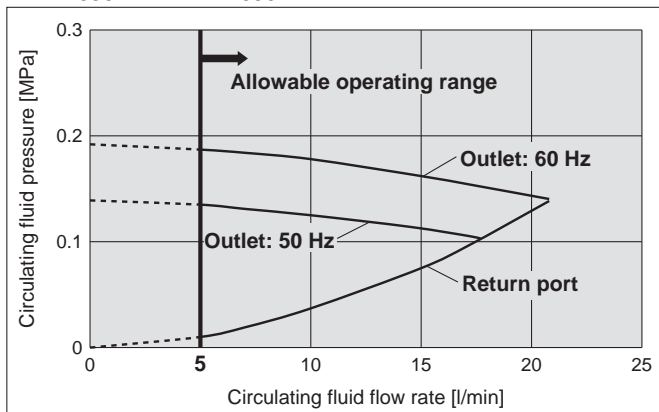

Required Facility Water Flow Rate

HRR012-W, HRR018-W, HRR024-W
HRR030-W

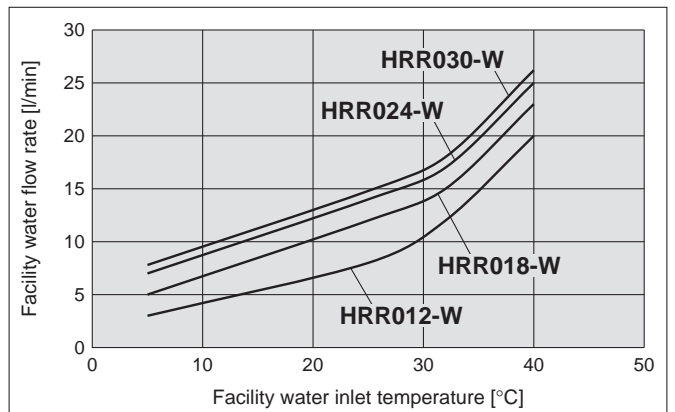

* This is the required facility water flow rate at the circulating fluid rated flow and the cooling capacity listed in the "Cooling Capacity" specifications.

Dimensions: Air-cooled Refrigeration

HRR012-A, HRR018-A

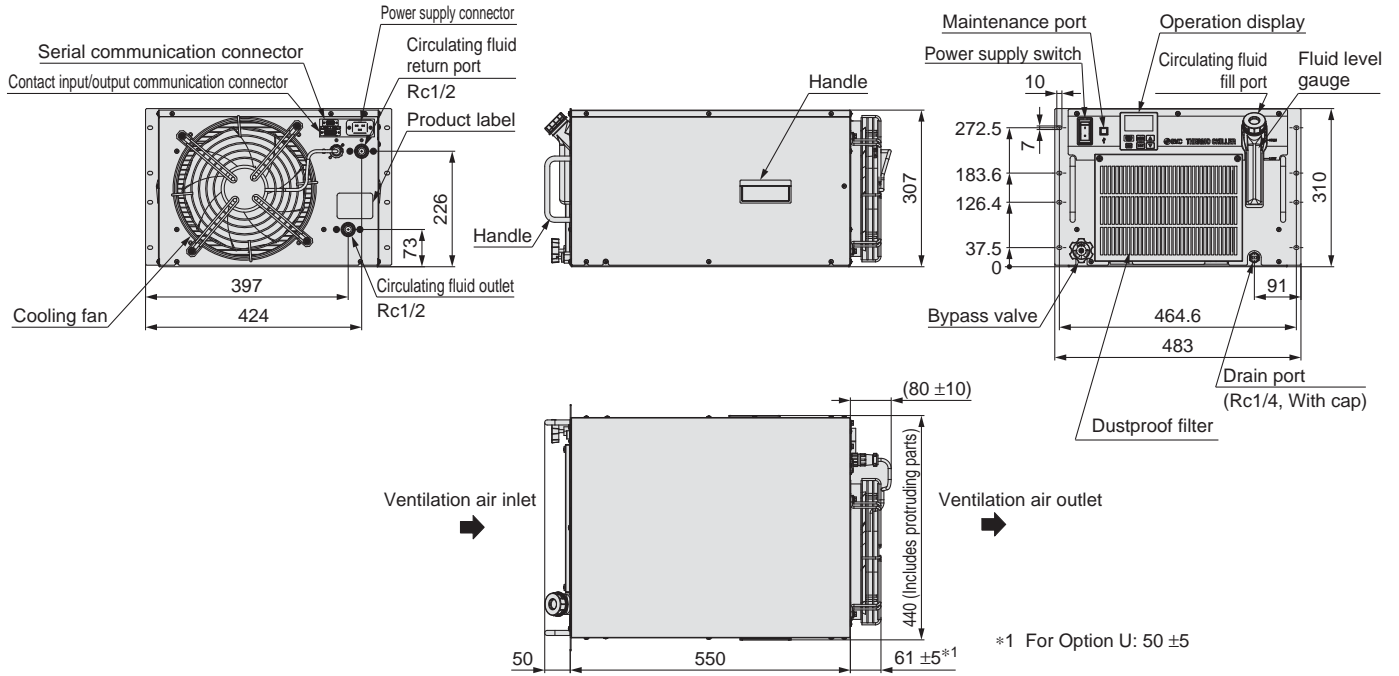

HRR024-A, HRR030-A

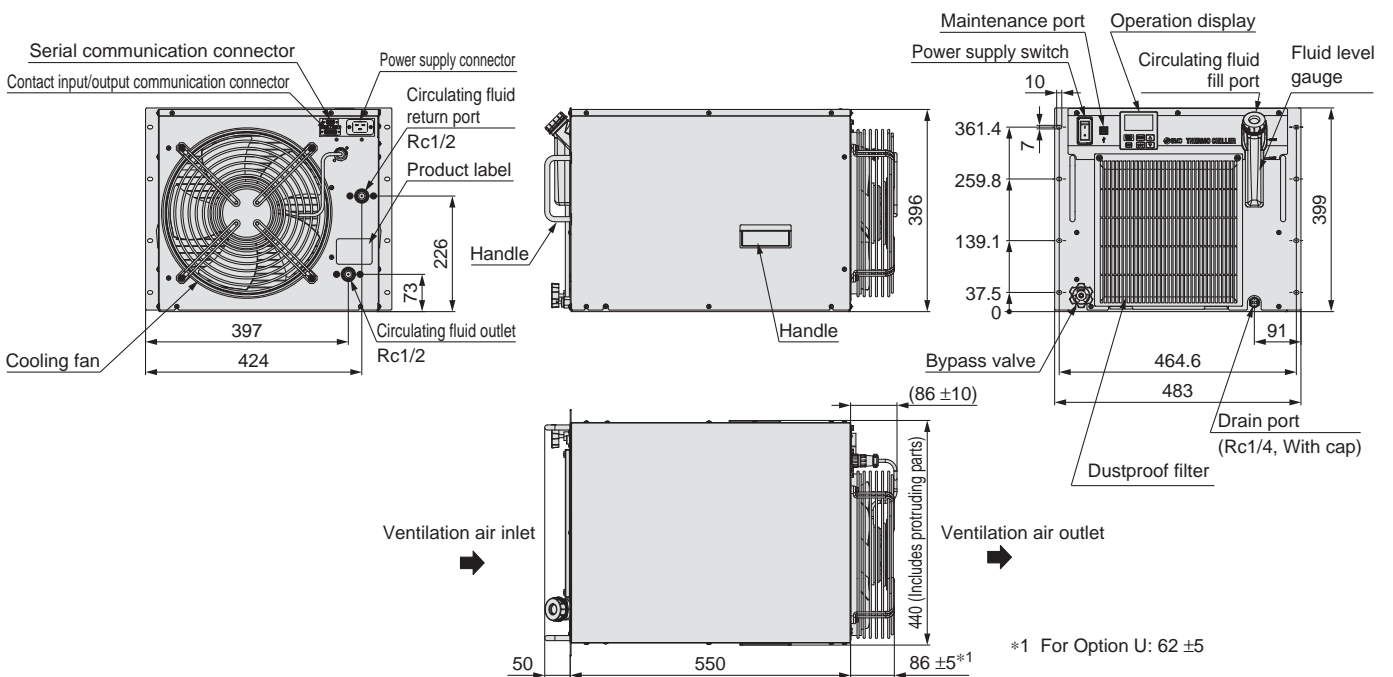

HRR Series

Dimensions: Water-cooled Refrigeration

HRR012-W, HRR018-W

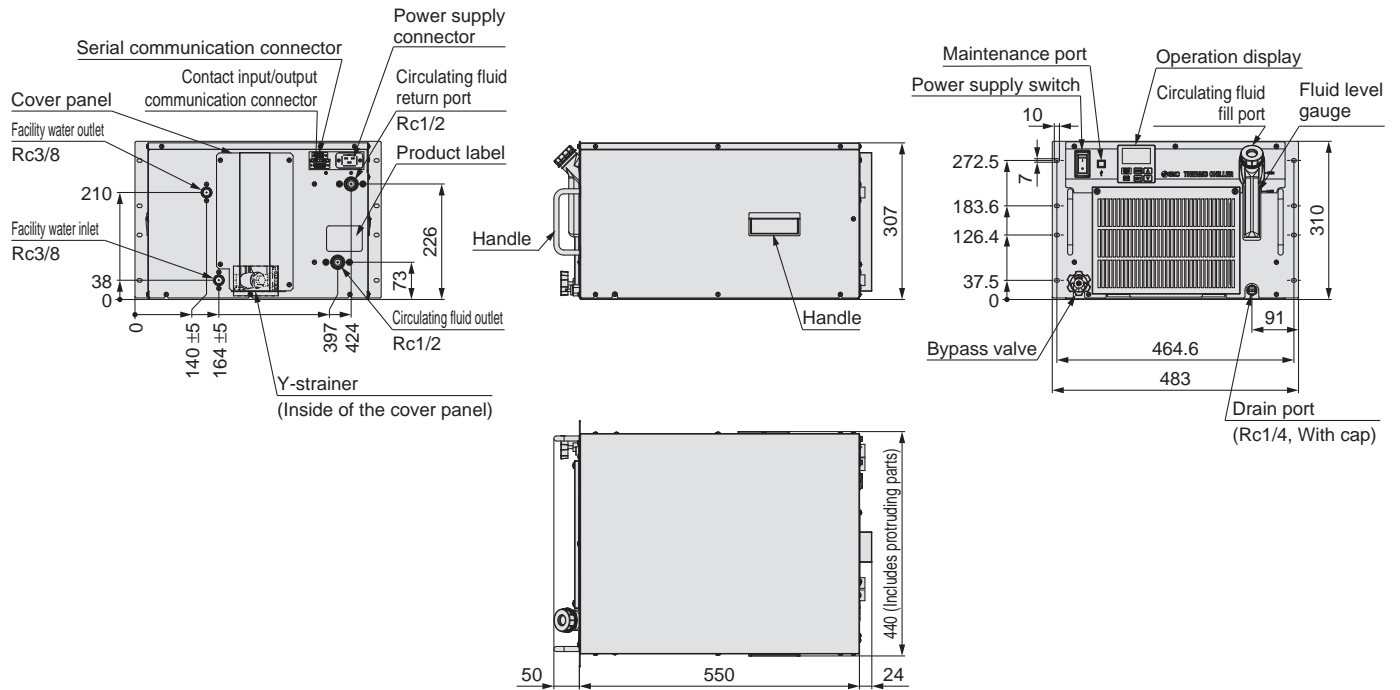

HRR024-W, HRR030-W

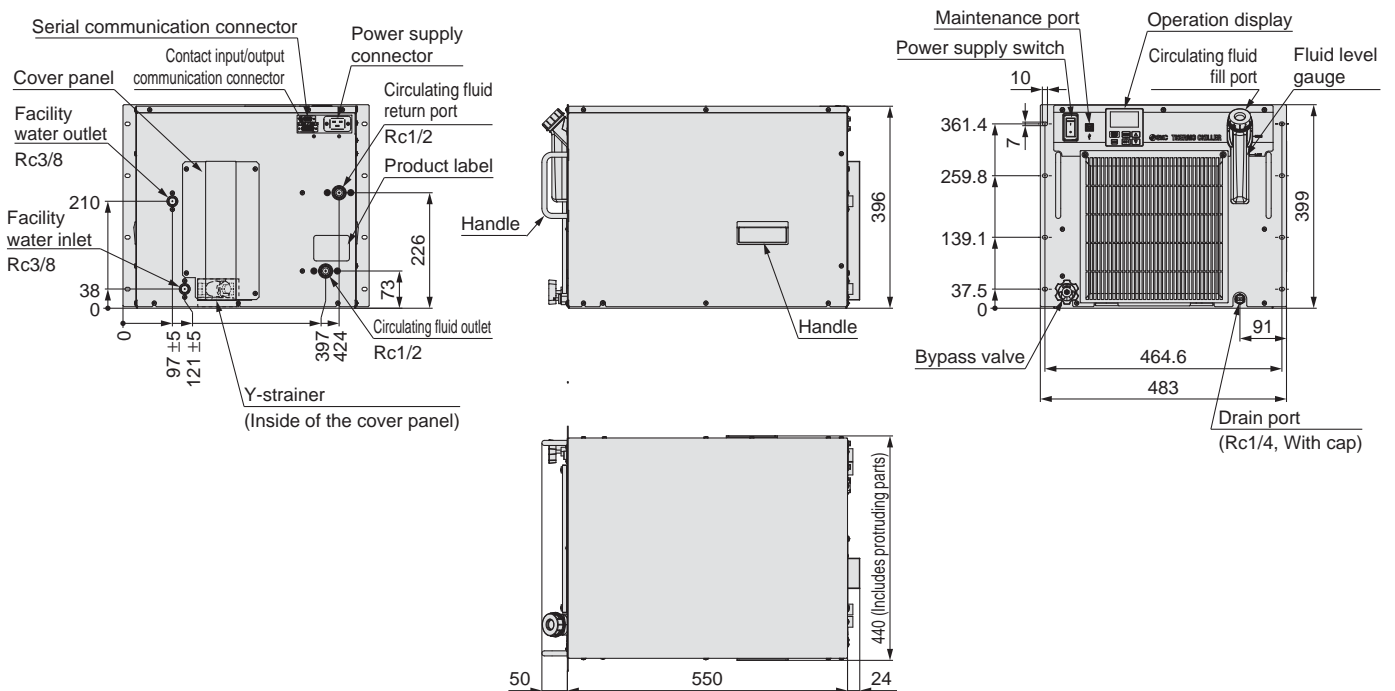

Operation Display Panel

The basic operation of this unit is controlled through the operation panel on the front of the product.

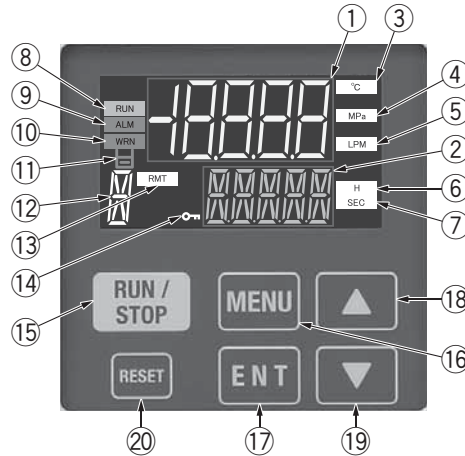

No.	Description	Function
①	Digital display (7-segment, 5 digits)	Displays the current circulating fluid discharge temperature, pressure, flow rate, alarm codes, and other set values
②	Digital display (11-segment, 5 digits)	Displays the circulating fluid discharge temperature and the set values of other menu items
③	[°C] lamp	Lights up when temperature is displayed on the digital display
④	[MPa] lamp	Lights up when pressure is displayed on the digital display
⑤	[LPM] lamp	Lights up when flow rate is displayed on the digital display
⑥	[H] lamp	Lights up when time is displayed on the digital display
⑦	[SEC] lamp	Lights up when seconds are displayed on the digital display
⑧	[RUN] lamp	Lights up during operation, and goes off when it is stopped
⑨	[ALM] lamp	Lights up when the FLT alarm occurs (This product will stop.)
⑩	[WRN] lamp	Lights up when the WRN alarm occurs (This product will continue operation.)
⑪	[] lamp	Lights up when "AL.01 Low level in tank abnormal" or "AL.02 Low level in tank" alarm is generated
⑫	Digital display (11-segment, 1 digit)	"X" is displayed when maintenance notification is generated.
⑬	[RMT] lamp	Lights up during remote operation by communication function
⑭	[KEYLOCK] lamp	Lights up when key lock setting is active
⑮	[RUN/STOP] key	Press and hold for 1 second to start or stop.
⑯	[MENU] key	Switching of each menu and cancellation of setting values
⑰	[ENT] key	Switch to setting mode and set values.
⑱	[▲] key	Move item upward or increase the set value.
⑲	[▼] key	Move item downward or decrease the set value.
⑳	[RESET] key	Reset the alarm.

Alarm

Displaying of the type of alarm and alarm code take place simultaneously. Type of alarm is displayed in (1) and alarm code is displayed in (9) of the operation display panel at the same. The alarm can be read out through communication.

Alarm code	Alarm message	Initial value	Display unit	
			Upper stage (White)	Lower stage (Green)
AL01	Low level in tank abnormal	FLT	AL01	LOW ⇒ LEVEL ⇒ FLT
AL02	Low level in tank	WRN	AL02	LOW ⇒ LEVEL ⇒ WRN
AL04	Water leakage	WRN* ¹	AL04	WATER ⇒ LEAK
AL09	Circulating fluid discharge pressure rise	FLT* ²	AL09	HIGH ⇒ PRESS
AL10	Flow rate reduction	WRN* ¹	AL10	LOW ⇒ FLOW ⇒ WRN
AL11	Outside ambient temperature range* ³	OFF* ¹	AL11	AMB ⇒ TEMP ⇒ OUT
AL12	Electric conductivity rise* ⁴	WRN	AL12	DI ⇒ ERROR
AL13	NOT TEMP READY	OFF* ¹	AL13	TEMP ⇒ READY ⇒ ERROR
AL14	Circulating fluid temperature range rise	OFF* ¹	AL14	TEMP ⇒ OUT.HI
AL15	Circulating fluid temperature range drop	OFF* ¹	AL15	TEMP ⇒ OUT.LO
AL17	Flow rate failure	FLT	AL17	LOW ⇒ FLOW ⇒ FLT
AL18	High circulating fluid discharge temp.	FLT	AL18	TEMP ⇒ FLT

Alarm code	Alarm message	Initial value	Display unit	
			Upper stage (White)	Lower stage (Green)
AL19	High circulating fluid return temp.	FLT	AL19	RET ⇒ TEMP ⇒ FLT
AL21	High circulating fluid discharge pressure	FLT	AL21	HIGH ⇒ PRESS ⇒ FLT
AL24	Memory abnormal	FLT	AL24	MEM ⇒ ERROR
AL25	Contact input 1 signal detection	FLT* ¹	AL25	INP1 ⇒ ERROR
AL26	Contact input 2 signal detection	FLT* ¹	AL26	INP2 ⇒ ERROR
AL27	Forced a stop	FLT	AL27	FORCE ⇒ STOP
AL28	Maintenance notice	OFF* ¹	AL28	MANT ⇒ ALARM
AL29	Communication error	WRN* ¹	AL29	COMM ⇒ ERROR
AL30	Refrigerant circuit abnormal	FLT	AL30	REF ⇒ ERROR ⇒ 0000
AL31	Sensor abnormal	FLT	AL31	SENS ⇒ ERROR ⇒ 0000
AL32	Controller abnormal	FLT	AL32	CTRL ⇒ ERROR ⇒ 0000

*1 Selectable from OFF/WRN/FLT
 · OFF: Disables the alarm function
 · WRN: Operation of this product will continue when the alarm occurs.
 · FLT: Operation of this product will stop when the alarm occurs.

*2 Selectable from WRN/FLT
 *3 Only air-cooled refrigeration type can be set.
 *4 Option DM (With electric conductivity control function + Applicable to DI water piping) only. When entering the range, the alarm is released automatically.

Communication Functions

Contact Input/Output Communication Specifications

Item		Specifications	
Contact input signal 1, 2	Insulation method	Photocoupler	
	Rated input voltage	24 VDC	
	Operating voltage range	21.6 to 26.4 VDC	
	Rated input current	5 mA TYP	
	Input impedance	4.7 kΩ	
Contact output signal 1, 2, 3	Rated load voltage	48 VAC or less/30 VDC or less	
	Maximum load current	500 mA AC/DC (Resistance load)	
	Minimum load current	5 VDC 10 mA	
24 VDC Output voltage		24 VDC ±10 % 500 mA MAX*1 (No inductive load)	

*1 When using the power supply of this product, make sure that the total load current is 500 mA or less.

Contact Input/Output Pin Nos.

Pin no.	Application	Division	Initial value (Default setting)
1	24 VDC output	Output	—
2	24 VDC output	Output	—
3	24 VDC output	Output	—
4	Contact input signal 1	Input	OFF
5	Common of contact output signal 1	Output	—
6	Common of contact output signal 2	Output	—
7	Common of contact output signal 3	Output	—
8	None	—	—
9	24 COM output	Output	—
10	24 COM output	Output	—
11	Common of contact input signal	Output	—
12	Contact input signal 2	Input	OFF
13	Contact output signal 1	Output	Run status signal (N.O. type)
14	Contact output signal 2	Output	Remote status signal (N.O. type)
15	Contact output signal 3	Output	Alarm signal (N.C. type)

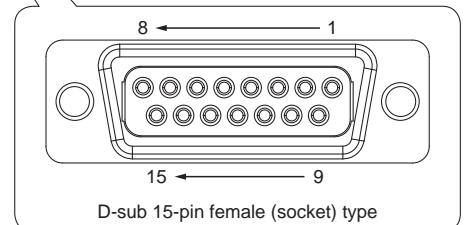
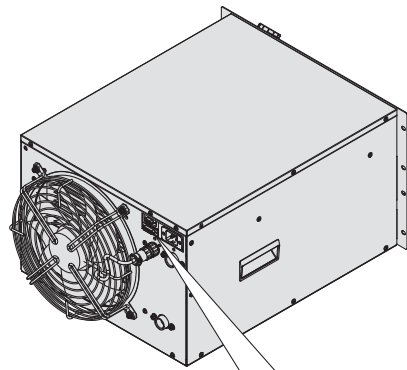

Contact input/output signal connector

For details, refer to the "Operation Manual" on the website, www.smc.eu

Communication Functions

Serial Communication

The serial communication (RS-485/RS-232C) enables the following items to be written and read out.

Writing	Readout	
Run/Stop Circulating fluid temperature setting	Circulating fluid discharge temperature Status information Circulating fluid flow rate Alarm occurrence information Circulating fluid discharge pressure Electric conductivity*1	*1 When using the Option DM

Item	Specifications
Connector type	D-sub 9-pin female connector
Standards	EIA Standards, RS-485 (ASCII mode/RTU mode)
Circuit diagram	
Standards	EIA Standards, RS-232C
Circuit diagram	

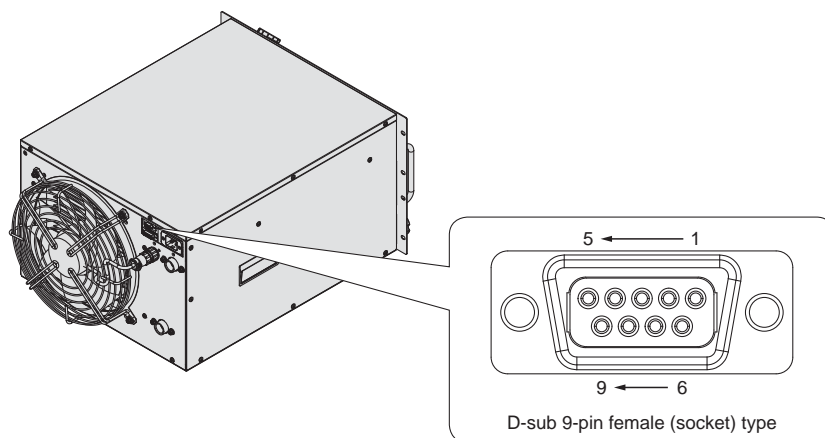

Communication connector

HRR Series Options

* Options have to be selected when ordering the thermo-chiller. It is not possible to add them after purchasing the unit.

DM

Option symbol

With Electric Conductivity Control Function, Applicable to DI Water Piping

HRR --20-DM

• With electric conductivity control function, Applicable to DI water piping

By entering the set value of electric conductivity and hysteresis, flow of circulating fluid to the DI filter is controlled by the solenoid valve to control electric conductivity. Contact material of the circulating fluid circuit is made from non-copper materials. (For details, refer to Option M.)

Applicable model	HRR012/018/024/030- <input type="text"/> <input type="text"/> -20-DM
Measurement range of electric conductivity	2.0 to 48.0 $\mu\text{S/cm}$
Set range of target electric conductivity	5.0 to 45.0 $\mu\text{S/cm}^{*1}$
Set range of electric conductivity hysteresis	2.0 to 10.0 $\mu\text{S/cm}$

*1 Default setting is set to "Electric conductivity set value: 25.0 $\mu\text{S/cm}$ " and "Hysteresis: 5.0 $\mu\text{S/cm}$."

Example of operation of electric conductivity control

- Electric conductivity target value : 25.0 [$\mu\text{S/cm}$]
- Electric conductivity control hysteresis: 5.0 [$\mu\text{S/cm}$]

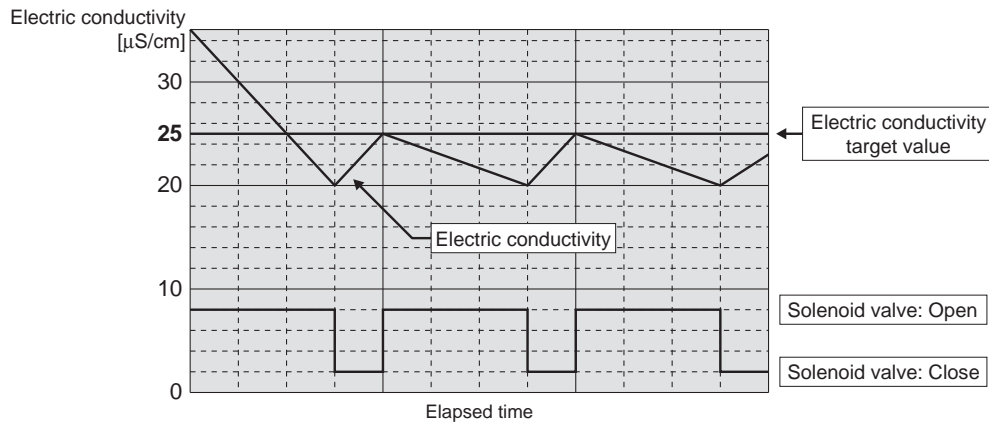

M

Option symbol

Applicable to DI Water Piping

HRR --20-M

• Applicable to DI water piping

Contact material of the circulating fluid circuit is made from non-copper materials.

- Available DI water is electric conductivity: 2 $\mu\text{S/cm}$ or more. (Electric resistivity: 0.5 $\text{M}\Omega\cdot\text{cm}$ or less)
- This Option M does not have electric resistance/electric conductivity control function. If this function is necessary, Option DM should be selected.

Applicable model	HRR012/018/024/030- <input type="text"/> <input type="text"/> -20-M
Contact material for circulating fluid	Stainless steel (including heat exchanger brazing), Alumina ceramic, SiC, Carbon, PP, PE, POM, PA, FKM, EPDM, PVC, PPS, AS

* No change in external dimensions

* Options have to be selected when ordering the thermo-chiller. It is not possible to add them after purchasing the unit.

T Option symbol
High-Pressure Pump Mounted

HRR □□-□□-20-T/MT

● High-pressure pump mounted

Possible to choose a high-pressure pump in accordance with user's piping resistance. Cooling capacity will decrease by heat generated in the pump.

- The high-pressure pump uses a mechanical seal.
- The thermo-chiller indicates maintenance notification when driving time is passed a recommended preventive maintenance hours. Please contact to service centre to ask for maintenance of the pump and mechanical seal.

Applicable model			HRR012/018/024/030-□□-20-T	HRR012/018/024/030-□□-20-MT*1
Pump	Rated flow (50/60 Hz)*2, 3	l/min	10 (0.42 MPa)/14 (0.40 MPa)	10 (0.32 MPa)/14 (0.32 MPa)
	Maximum pump head (50/60 Hz)	m	50	50
	Output	W	550	
Circuit protector		A	15 A (10 A for standard)	
Recommended earth leakage breaker capacity		A	15	
Cooling capacity*4		W	The cooling capacity reduces about 300 W from the value in the catalogue. (due to an increase in the heat generation of the pump)	

- *1 Option MT: Applicable to DI water piping + High-pressure pump mounted
- *2 The capacity at the thermo-chiller outlet when the circulating fluid temperature is 20 °C.
- *3 Required minimum flow rate for maintaining the cooling capacity or temperature stability
- *4 Cooling capacity will decrease as pump power increases.
- * When the option, high-pressure pump mounted, is selected, the product weight increases by 5 kg.
- * No change in external dimensions of this product

Pump Capacity

HRR012/018/024/030-□□-20-T

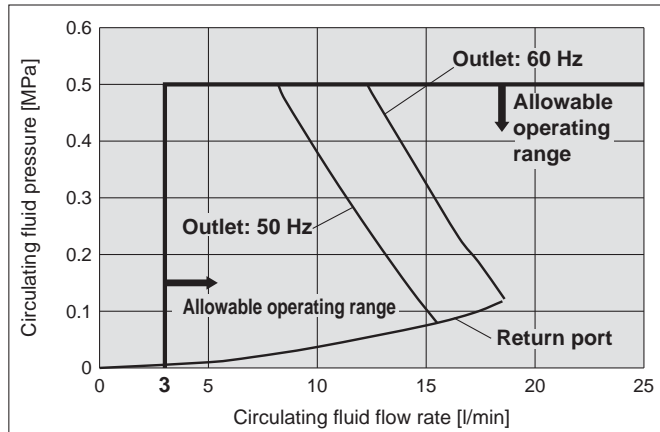

HRR012/018/024/030-□□-20-MT

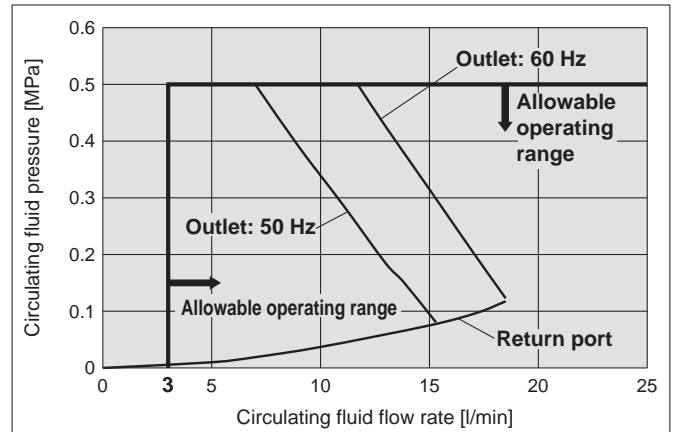

HRR Series

Optional Accessories

① Concentration Meter

This meter can be used to control the concentration of ethylene glycol aqueous solution regularly.

Part number	Applicable model
HRZ-BR002	HRR012/018/024/030-□□-20

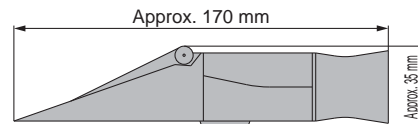

② Particle Filter Element for Replacement

Element for the maintenance of the particle filter for circulating fluid

Part number	Applicable model
EJ202S-005X11	HRR012/018/024/030-□□-20

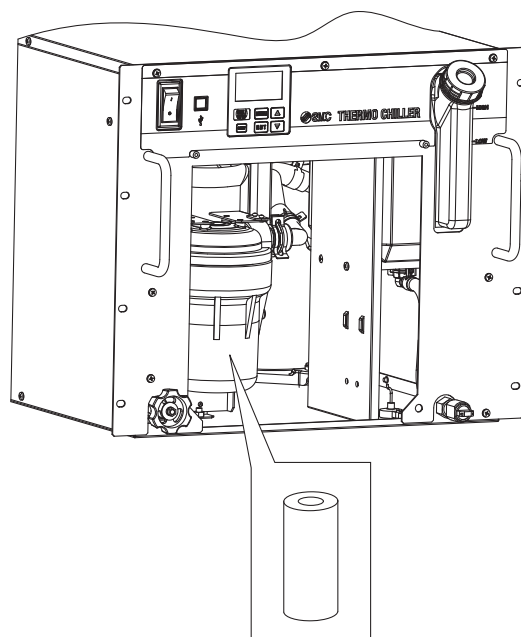

③ DI Filter Replacement Cartridge

DI filter cartridge for replacement for Option DM [Electric conductivity control type, DI water piping type]

Part number	Applicable model
HRR-DF001	HRR012/018/024/030-□□-20-DM□



Cooling Capacity Calculation

Required Cooling Capacity Calculation

Example 1: When the heat generation amount in the user's equipment is known.

The heat generation amount can be determined based on the power consumption or output of the heat generating area — i.e. the area requiring cooling — within the user's equipment.*1

Q: Heat generation amount

① Derive the heat generation amount from the power consumption.

Power consumption P: 1000 [W]

$$Q = P = 1000 \text{ [W]}$$

Cooling capacity = Considering a safety factor of 20 %,

$$1000 \text{ [W]} \times 1.2 = 1200 \text{ [W]}$$

② Derive the heat generation amount from the power supply output.

Power supply output VI: 1.0 [kVA]

$$Q = P = V \times I \times \text{Power factor}$$

In this example, using a power factor of 0.85:

$$= 1.0 \text{ [kVA]} \times 0.85 = 0.85 \text{ [kW]} = 850 \text{ [W]}$$

Cooling capacity = Considering a safety factor of 20 %,

$$850 \text{ [W]} \times 1.2 = 1020 \text{ [W]}$$

③ Derive the heat generation amount from the output.

Output (shaft power, etc.) W: 800 [W]

$$Q = P = \frac{W}{\text{Efficiency}}$$

In this example, using an efficiency of 0.7:

$$= \frac{800}{0.7} = 1143 \text{ [W]}$$

Cooling capacity = Considering a safety factor of 20 %,

$$1143 \text{ [W]} \times 1.2 = 1372 \text{ [W]}$$

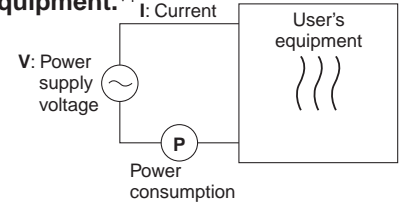

*1 The examples above calculate the heat generation amount based on the power consumption. The actual heat generation amount may differ due to the structure of the user's equipment. Be sure to check it carefully.

Example 2: When the heat generation amount in the user's equipment is not known.

Obtain the temperature difference between inlet and outlet by circulating the circulating fluid inside the user's equipment.

- Heat generation amount by user's equipment Q : Unknown [W] ([J/s])
- Circulating fluid : Tap water*1
- Circulating fluid mass flow rate q_m : ($= \rho \times q_v \div 60$) [kg/s]
- Circulating fluid density ρ : 1 [kg/dm³]
- Circulating fluid (volume) flow rate q_v : 10 [dm³/min]
- Circulating fluid specific heat C : 4.2×10^3 [J/(kg·K)]
- Circulating fluid outlet temperature T₁ : 293 [K] (20 [°C])
- Circulating fluid return temperature T₂ : 295 [K] (22 [°C])
- Circulating fluid temperature difference ΔT : 2.0 [K] ($= T_2 - T_1$)
- Conversion factor: minutes to seconds (SI units) : 60 [s/min]

*1 Refer to page 23 for the typical physical property value of tap water or other circulating fluids.

$$Q = q_m \times C \times (T_2 - T_1)$$

$$= \frac{\rho \times q_v \times C \times \Delta T}{60} = \frac{1 \times 10 \times 4.2 \times 10^3 \times 2.0}{60}$$

$$= 1400 \text{ [J/s]} \approx 1400 \text{ [W]}$$

Cooling capacity = Considering a safety factor of 20 %,

$$1400 \text{ [W]} \times 1.2 = 1680 \text{ [W]}$$

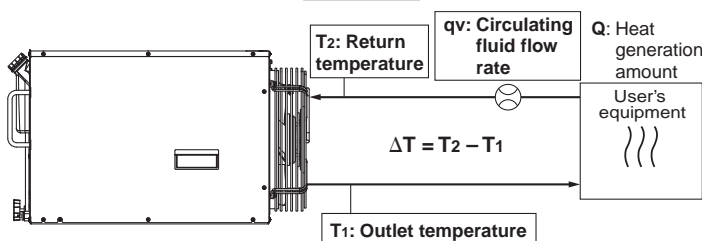

Example of current measurement units (Reference)

- Heat generation amount by user's equipment Q : Unknown [cal/h] → [W]
- Circulating fluid : Tap water*1
- Circulating fluid weight flow rate q_m : ($= \rho \times q_v \times 60$) [kgf/h]
- Circulating fluid weight volume ratio γ : 1 [kgf/L]
- Circulating fluid (volume) flow rate q_v : 10 [l/min]
- Circulating fluid specific heat C : 1.0×10^3 [cal/(kgf·°C)]
- Circulating fluid outlet temperature T₁ : 20 [°C]
- Circulating fluid return temperature T₂ : 22 [°C]
- Circulating fluid temperature difference ΔT : 2.0 [°C] ($= T_2 - T_1$)
- Conversion factor: hours to minutes : 60 [min/h]
- Conversion factor: kcal/h to kW : 860 [(cal/h)/W]

$$Q = \frac{q_m \times C \times (T_2 - T_1)}{860}$$

$$= \frac{\gamma \times q_v \times 60 \times C \times \Delta T}{860}$$

$$= \frac{1 \times 10 \times 60 \times 1.0 \times 10^3 \times 2.0}{860}$$

$$= \frac{1200000 \text{ [cal/h]}}{860}$$

$$\approx 1400 \text{ [W]}$$

Cooling capacity = Considering a safety factor of 20 %,

$$1400 \text{ [W]} \times 1.2 = 1680 \text{ [W]}$$

* Calculation example for the temperature and flow rate based on customer's piping condition. For calculating the required cooling capacity based on the displayed value of temperature and flow rate in the chiller, fully close the bypass valve.

Required Cooling Capacity Calculation

Example 3: When there is no heat generation, and when cooling the object below a certain temperature and period of time.

Heat quantity by cooled substance (per unit time) **Q**: Unknown [W] [(J/s)]
 Cooled substance : Water
 Cooled substance mass **m** : (= $\rho \times V$) [kg]
 Cooled substance density ρ : 1 [kg/dm³]
 Cooled substance total volume **V** : 20 [dm³]
 Cooled substance specific heat **C** : 4.2 x 10³ [J/(kg·K)]
 Cooled substance temperature when cooling begins **To**: 305 [K] (32 [°C])
 Cooled substance temperature after t hour **Tt** : 293 [K] (20 [°C])
 Cooling temperature difference ΔT : 12 [K] (= $T_o - T_t$)
 Cooling time Δt : 900 [s] (= 15 [min])

* Refer to the following for the typical physical property values by circulating fluid.

$$Q = \frac{m \times C \times (T_o - T_t)}{\Delta t} = \frac{\rho \times V \times C \times \Delta T}{\Delta t}$$

$$= \frac{1 \times 20 \times 4.2 \times 10^3 \times 12}{900} = 1120 \text{ [J/s]} \approx 1120 \text{ [W]}$$

Cooling capacity = Considering a safety factor of 20 %,

$$1120 \text{ [W]} \times 1.2 = 1344 \text{ [W]}$$

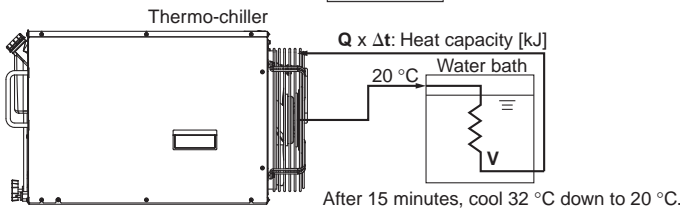

* This is the calculated value by changing the fluid temperature only.
 Thus, it varies substantially depending on the water bath or piping shape.

Example of current measurement units (Reference)

Heat quantity by cooled substance (per unit time) **Q**: Unknown [cal/h] → [W]
 Cooled substance : Water
 Cooled substance weight **m** : (= $\rho \times V$) [kgf]
 Cooled substance weight volume ratio γ : 1 [kgf/L]
 Cooled substance total volume **V** : 20 [L]
 Cooled substance specific heat **C** : 1.0 x 10³ [cal/(kgf·°C)]
 Cooled substance temperature when cooling begins **To** : 32 [°C]
 Cooled substance temperature after t hour **Tt**: 20 [°C]
 Cooling temperature difference ΔT : 12 [°C] (= $T_o - T_t$)
 Cooling time Δt : 15 [min]
 Conversion factor: hours to minutes : 60 [min/h]
 Conversion factor: kcal/h to kW : 860 [(cal/h)/W]

$$Q = \frac{m \times C \times (T_o - T_t)}{\Delta t \times 860} = \frac{\gamma \times V \times 60 \times C \times \Delta T}{\Delta t \times 860}$$

$$= \frac{1 \times 20 \times 60 \times 1.0 \times 10^3 \times 12}{15 \times 860}$$

$$\approx 1120 \text{ [W]}$$

Cooling capacity = Considering a safety factor of 20 %,

$$1120 \text{ [W]} \times 1.2 = 1344 \text{ [W]}$$

Precautions on Cooling Capacity Calculation

1. Heating capacity

When the circulating fluid temperature is set above room temperature, it needs to be heated by the thermo-chiller. The heating capacity depends on the circulating fluid temperature. Consider the radiation rate and heat capacity of the user's equipment and check beforehand if the required heating capacity is provided.

2. Pump capacity

<Circulating fluid flow rate>

Circulating fluid flow rate varies depending on the circulating fluid discharge pressure. Consider the installation height difference between the thermo-chiller and the user's equipment, and the piping resistance such as circulating fluid pipings, or piping size, or piping curves in the machine. Check beforehand if the required flow is achieved, using the pump capacity curves.

<Circulating fluid discharge pressure>

Circulating fluid discharge pressure has the possibility to increase up to the maximum pressure in the pump capacity curves. Check beforehand if the circulating fluid pipings or circulating fluid circuit of the user's equipment are fully durable against this pressure.

Circulating Fluid Typical Physical Property Values

1. This catalogue uses the following values for density and specific heat in calculating the required cooling capacity.

Density ρ : 1 [kg/dm³] (or, using current unit system, weight volume ratio $\gamma = 1$ [kgf/L])
 Specific heat **C**: 4.19 x 10³ [J/(kg·K)] (or, using current unit system, 1 x 10³ [cal/(kgf·°C)])

2. Values for density and specific heat change slightly according to temperature shown below. Use this as a reference.

Water

Physical property value Temperature	Density ρ [kg/dm ³]	Specific heat C [J/(kg·K)]	Current unit system	
			Weight volume ratio γ [kgf/L]	Specific heat C [cal/(kgf·°C)]
5 °C	1.00	4.2 x 10 ³	1.00	1 x 10 ³
10 °C	1.00	4.19 x 10 ³	1.00	1 x 10 ³
15 °C	1.00	4.19 x 10 ³	1.00	1 x 10 ³
20 °C	1.00	4.18 x 10 ³	1.00	1 x 10 ³
25 °C	1.00	4.18 x 10 ³	1.00	1 x 10 ³
30 °C	1.00	4.18 x 10 ³	1.00	1 x 10 ³
35 °C	0.99	4.18 x 10 ³	0.99	1 x 10 ³
40 °C	0.99	4.18 x 10 ³	0.99	1 x 10 ³

15% Ethylene Glycol Aqueous Solution

Physical property value Temperature	Density ρ [kg/dm ³]	Specific heat C [J/(kg·K)]	Current unit system	
			Weight volume ratio γ [kgf/L]	Specific heat C [cal/(kgf·°C)]
5 °C	1.02	3.91 x 10 ³	1.02	0.93 x 10 ³
10 °C	1.02	3.91 x 10 ³	1.02	0.93 x 10 ³
15 °C	1.02	3.91 x 10 ³	1.02	0.93 x 10 ³
20 °C	1.01	3.91 x 10 ³	1.01	0.93 x 10 ³
25 °C	1.01	3.91 x 10 ³	1.01	0.93 x 10 ³
30 °C	1.01	3.91 x 10 ³	1.01	0.94 x 10 ³
35 °C	1.01	3.91 x 10 ³	1.01	0.94 x 10 ³
40 °C	1.01	3.92 x 10 ³	1.01	0.94 x 10 ³

* Shown above are reference values. Contact circulating fluid supplier for details.



HRR Series Specific Product Precautions 1

Be sure to read this before handling the products. Refer to the back cover for safety instructions. For temperature control equipment precautions, refer to the “Handling Precautions for SMC Products” and the “Operation Manual” on the SMC website: <http://www.smc.eu>

Design

Warning

1. This catalogue shows the specifications of a single unit.

- 1) Check the specifications of the single unit (contents of this catalogue) and thoroughly consider the adaptability between the user's system and this unit.
- 2) Although the protection circuit as a single unit is installed, prepare a drain pan, water leakage sensor, discharge air facility, and emergency stop equipment, depending on the user's operating condition. Also, the user is requested to carry out the safety design for the whole system.

2. When attempting to cool areas that are open to the atmosphere (tanks, pipes), plan your piping system accordingly.

When cooling open-air external tanks, arrange the piping so that there are coil pipes for cooling inside the tanks, and to carry back the entire flow volume of circulating fluid that is released.

3. Use non-corrosive material for fluid contact parts of circulating fluid.

The recommended circulating fluid is the tap water or 15% ethylene glycol aqueous solution. Using corrosive materials such as aluminium or iron for fluid contact parts such as piping may cause clogging or leakage in the circulating fluid circuit. Therefore, take sufficient care when selecting fluid contact part materials such as piping.

4. Design the piping so that no foreign matter enter the chiller.

If foreign matter such as scales in the piping enter the circulating fluid, this may cause the pump to malfunction.

Selection

Warning

1. Model selection

For selecting a model of thermo-chiller, it is required to know the heat generation amount of the user's equipment. Obtain the heat generation amount, referring to “Cooling Capacity Calculation” on pages 22 and 23 before selecting a model.

Handling

Warning

1. Thoroughly read the Operation Manual.

Read the Operation Manual completely before operation, and keep this manual available whenever necessary.

Transportation / Carriage / Movement

Warning

1. This product is heavy. Pay attention to safety and position of the product when it is transported, carried and moved.

2. Read the Operation Manual carefully to move the product after unpacking.

Caution

1. Never put the product down sideways as this may cause failure.

The product will be delivered in the packaging shown below.

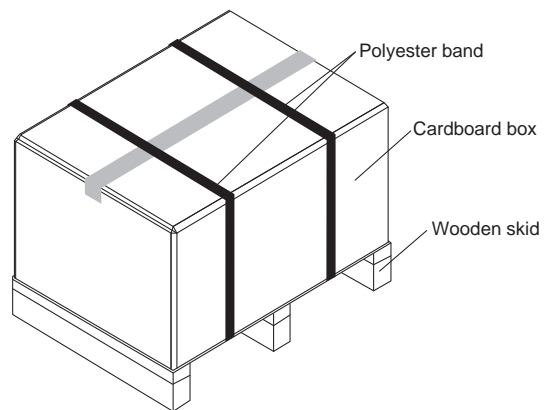

Model	Weight [kg]*1	Dimensions [mm]
HRR012-A HRR018-A	54	Height 575 x Width 610 x Depth 820
HRR012-W HRR018-W	55	
HRR024-A HRR030-A	61	Height 665 x Width 610 x Depth 820
HRR024-W HRR030-W	60	

*1 For models with an option, the weights are increased as below.

Option	Description	Additional weight
DM	With electric conductivity control function, Applicable to DI water piping	+1 kg
M	Applicable to DI water piping	Not changed
T	High-pressure pump mounted	+5 kg



HRR Series

Specific Product Precautions 2

Be sure to read this before handling the products. Refer to the back cover for safety instructions. For temperature control equipment precautions, refer to the "Handling Precautions for SMC Products" and the "Operation Manual" on the SMC website: <http://www.smc.eu>

Operating Environment / Storage Environment

Warning

1. Do not use in the following environment as it will lead to a breakdown.

- 1) Outdoors
- 2) In locations where water, water vapour, salt water, and oil may splash on the product.
- 3) In locations where there are dust and particles.
- 4) In locations where corrosive gases, organic solvents, chemical fluids, or flammable gases are present. (This product is not explosion proof.)
- 5) In locations where the ambient temperature exceeds the limits as mentioned below.
 During transportation/storage: 0 to 50 °C (But as long as water or circulating fluid are not left inside the pipings)
 During operation: 5 to 40 °C
- 6) In locations where the ambient humidity is out of the following range or where condensation occurs.
 During transportation/storage: 15 to 85 %
 During operation: 30 to 70 %
- 7) In locations which receive direct sunlight or radiated heat.
- 8) In locations where there is a heat source nearby and the ventilation is poor.
- 9) In locations where temperature substantially changes.
- 10) In locations where strong magnetic noise occurs. (In locations where strong electric fields, strong magnetic fields and surge voltage occur.)
- 11) In locations where static electricity occurs, or conditions which make the product discharge static electricity.
- 12) In locations where high frequency occurs.
- 13) In locations where damage is likely to occur due to lightning.
- 14) In locations at altitude of 3000 m or higher (Except during storage and transportation)
 * For altitude of 1000 m or higher
 Because of lower air density, the heat radiation efficiencies of the devices in the product will be lower in the location at altitude of 1000 m or higher. Therefore, the maximum ambient temperature to use and the cooling capacity will lower according to the descriptions in the table below.

Select the thermo-chiller considering the descriptions.

- ① Upper limit of ambient temperature: Use the product in ambient temperature of the described value or lower at each altitude.
- ② Cooling capacity coefficient: The product's cooling capacity will lower to one that multiplied by the described value at each altitude.

Altitude [m]	① Upper limit of ambient temperature [°C]		② Cooling capacity coefficient
	40 °C products		
Less than 1000 m	40		1.00
Less than 1500 m	38		0.85
Less than 2000 m	36		0.80
Less than 2500 m	34		0.75
Less than 3000 m	32		0.70

- 15) In locations where strong impacts or vibrations occur.
- 16) In locations where a massive force strong enough to deform the product is applied or a weight from a heavy object is applied.
- 17) In locations where there is not sufficient space for maintenance.

2. Install in an environment where the unit will not come into direct contact with rain or snow.

These models are for indoor use only.
Do not install outdoors where rain or snow may fall on them.

3. Conduct ventilation and cooling to discharge heat. (Air-cooled refrigeration)

The heat which is cooled down through air-cooled condenser is discharged.
When using in a room which is shut tightly, ambient temperature will exceed the specification range stipulated in this catalogue, which will activate the safety detector and stop the operation. In order to avoid this situation, discharge the heat outside of a room by ventilation or cooling facilities.

4. The product is not designed for clean room usage. It generates particles internally.



HRR Series Specific Product Precautions 3

Be sure to read this before handling the products. Refer to the back cover for safety instructions. For temperature control equipment precautions, refer to the "Handling Precautions for SMC Products" and the "Operation Manual" on the SMC website: <http://www.smc.eu>

Mounting / Installation

Warning

1. Do not use the product outdoors.
2. Do not place heavy objects on top of this product, or step on it.
The external panel can be deformed and danger can result.

Caution

1. Make sure that the rack and the rack rail can support the weight of the product.
2. Refer to the Operation Manual for this product, and secure an installation space that is necessary for the maintenance and ventilation.

<Air-cooled refrigeration>

1. The air-cooled type product exhausts heat using the fan that is mounted to the product. If the product is operated with insufficient ventilation, ambient temperature may exceed 40 °C, and this will affect the performance and life of the product. To prevent this ensure that suitable ventilation is available (see below).
2. For installation indoors, ventilation ports and a ventilation fan should be equipped as needed.

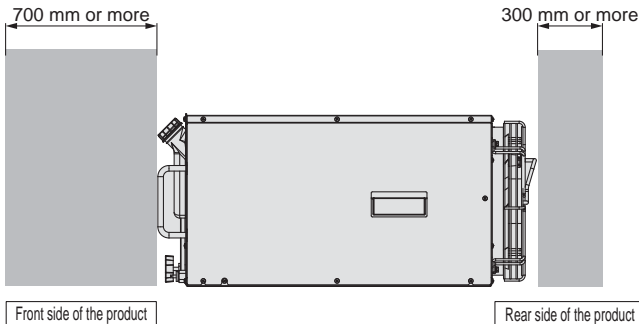

<Heat radiation amount/Required ventilation rate>

Model	Heat radiation amount [kW]	Required ventilation rate [m ³ /min]	
		Differential temp. of 3° C between inside and outside of installation area	Differential temp. of 6 °C between inside and outside of installation area
HRR012-A	Approx. 2	40	20
HRR018-A	Approx. 4	70	40
HRR024-A	Approx. 5	90	50
HRR030-A	Approx. 6	100	60

Piping

Caution

1. Regarding the circulating fluid pipings, consider carefully the suitability for shutoff pressure, temperature and circulating fluid.
If the operating performance is not sufficient, the pipings may burst during operation. Also, using corrosive materials such as aluminium or iron for fluid contact parts such as piping may cause clogging or leakage in the circulating fluid and facility water circuits. Provide protection against corrosion when you use the product.
2. Select the piping port size which can exceed the rated flow.
For the rated flow, refer to the pump capacity table.
3. When tightening at the circulating fluid inlet and outlet, drain port or overflow port of this product, use a pipe wrench to clamp the connection ports.
4. This product series are constant-temperature fluid circulating machines with built-in tanks.
Do not install equipment on your system side such as pumps that forcibly return the circulating fluid to the unit. Also, if you attach an external tank that is open to the air, it may become impossible to circulate the circulating fluid. Proceed with caution.

Electrical Wiring

Warning

1. Grounding should never be connected to a water line, gas line or lightning rod.

Caution

1. Communication cable should be prepared by the customer.
2. Provide a stable power supply which is not affected by surge or distortion.
If the voltage increase ratio (dV/dt) at the zero cross should exceed 40 V/200 μsec., it may result in malfunction.

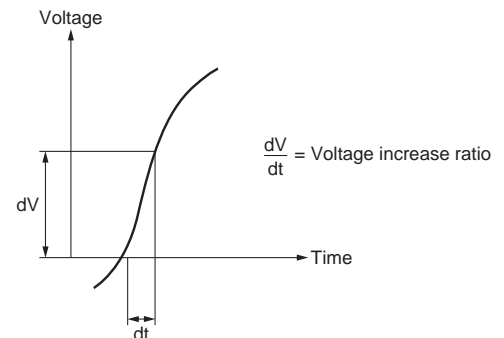



HRR Series Specific Product Precautions 4

Be sure to read this before handling the products. Refer to the back cover for safety instructions. For temperature control equipment precautions, refer to the "Handling Precautions for SMC Products" and the "Operation Manual" on the SMC website: <http://www.smc.eu>

Circulating Fluid

Caution

1. Avoid oil or other foreign matter entering the circulating fluid.
2. When water is used as a circulating fluid, use tap water that conforms to the appropriate water quality standards.
Use tap water that conforms to the standards shown below (including water used for dilution of ethylene glycol aqueous solution).

Tap Water (as Circulating Fluid) Quality Standards

The Japan Refrigeration and Air Conditioning Industry Association
JRA GL-02-1994 "Cooling water system – Circulation type – Make-up water"

	Item	Unit	Standard value	Influence	
				Corrosion	Scale generation
Standard item	pH (at 25°C)	—	6.0 to 8.0	○	○
	Electric conductivity (25°C)	[μS/cm]	100*1 to 300*1	○	○
	Chloride ion (Cl ⁻)	[mg/L]	50 or less	○	
	Sulfuric acid ion (SO ₄ ²⁻)	[mg/L]	50 or less	○	
	Acid consumption amount (at pH4.8)	[mg/L]	50 or less		○
	Total hardness	[mg/L]	70 or less		○
	Calcium hardness (CaCO ₃)	[mg/L]	50 or less		○
	Ionic state silica (SiO ₂)	[mg/L]	30 or less		○
Reference item	Iron (Fe)	[mg/L]	0.3 or less	○	○
	Copper (Cu)	[mg/L]	0.1 or less	○	
	Sulfide ion (S ₂ ⁻)	[mg/L]	Should not be detected.	○	
	Ammonium ion (NH ₄ ⁺)	[mg/L]	0.1 or less	○	
	Residual chlorine (Cl)	[mg/L]	0.3 or less	○	
	Free carbon (CO ₂)	[mg/L]	4.0 or less	○	

- *1 In the case of [MΩ·cm], it will be 0.003 to 0.01.
- : Factors that have an effect on corrosion or scale generation.
- Even if the water quality standards are met, complete prevention of corrosion is not guaranteed.

3. Use an ethylene glycol aqueous solution that does not contain additives such as preservatives.
4. When using ethylene glycol aqueous solution, maintain a maximum concentration of 15%.
Overly high concentrations can cause a pump overload. Low concentrations, however, can lead to freezing when circulating fluid temperature is 10 °C or lower and cause the thermo-chiller to break down.

5. A magnet pump or mechanical seal pump is used as the circulating pump for the circulating fluid.
It is particularly impossible to use liquid including metallic powder such as iron powder.

Facility Water Supply

Warning

<Water-cooled refrigeration>

1. The water-cooled refrigeration type thermo-chiller radiates heat to the facility water.
Prepare the facility water system that satisfies the heat radiation and the facility water specifications below.

Required facility water system

<Heat radiation amount/Facility water specifications>

Model	Heat radiation [kW]	Facility water specifications
HRR012-W	Approx. 2	Refer to "Facility water system" in the specifications.
HRR018-W	Approx. 4	
HRR024-W	Approx. 5	
HRR030-W	Approx. 6	

2. When using tap water as facility water, use tap water that conforms to the appropriate water quality standards.
Use tap water that conforms to the standards shown below.

<Tap Water (as Facility Water) Quality Standards>

The Japan Refrigeration and Air Conditioning Industry Association
JRA GL-02-1994 "Cooling water system – Circulation type – Circulating water"

	Item	Unit	Standard value	Influence	
				Corrosion	Scale generation
Standard item	pH (at 25°C)	—	6.5 to 8.2	○	○
	Electric conductivity (25°C)	[μS/cm]	100*1 to 800*1	○	○
	Chloride ion (Cl ⁻)	[mg/L]	200 or less	○	
	Sulfuric acid ion (SO ₄ ²⁻)	[mg/L]	200 or less	○	
	Acid consumption amount (at pH4.8)	[mg/L]	100 or less		○
	Total hardness	[mg/L]	200 or less		○
	Calcium hardness (CaCO ₃)	[mg/L]	150 or less		○
	Ionic state silica (SiO ₂)	[mg/L]	50 or less		○
Reference item	Iron (Fe)	[mg/L]	1.0 or less	○	○
	Copper (Cu)	[mg/L]	0.3 or less	○	
	Sulfide ion (S ₂ ⁻)	[mg/L]	Should not be detected.	○	
	Ammonium ion (NH ₄ ⁺)	[mg/L]	1.0 or less	○	
	Residual chlorine (Cl)	[mg/L]	0.3 or less	○	
	Free carbon (CO ₂)	[mg/L]	4.0 or less	○	

- *1 In the case of [MΩ·cm], it will be 0.001 to 0.01.
- : Factors that have an effect on corrosion or scale generation.
- Even if the water quality standards are met, complete prevention of corrosion is not guaranteed.

3. Supply pressure of 0.5 MPa or less.
If the supply pressure is high, it will cause water leakage.

4. Be sure to prepare your utilities so that the pressure of the thermo-chiller facility water outlet is at 0 MPa (atmospheric pressure) or more.
If the facility water outlet pressure becomes negative, the internal facility water piping may collapse, and proper flow control of facility water will be impossible.

Using deionised water as facility water may cause problems such as clogging in the piping due to metal ion.

Using deionised water as facility water may cause problems such as clogging in the piping due to metal ion.

5. Do not use fluid that includes metric powers and other foreign materials.
It can cause issues: clogging of the circulating fluid circuit or leakage.



HRR Series

Specific Product Precautions 5

Be sure to read this before handling the products. Refer to the back cover for safety instructions. For temperature control equipment precautions, refer to the "Handling Precautions for SMC Products" and the "Operation Manual" on the SMC website: <http://www.smc.eu>

Operation

Warning

1. Confirmation before operation

1) The fluid level of a tank should be within the specified range of "HIGH" and "LOW."

When exceeding the specified level, the circulating fluid will overflow.

2) Remove the air.

Conduct a trial operation, looking at the fluid level.

Since the fluid level will go down when the air is removed from the user's piping system, supply water once again when the fluid level is reduced. When there is no reduction in the fluid level, the job of removing the air is completed.

2. Confirmation during operation

• Check the circulating fluid temperature.

The operating temperature range of the circulating fluid is between 10 and 35°C.

When the amount of heat generated from the user's equipment is greater than the product's capability, the circulating fluid temperature may exceed this range. Use caution regarding this matter.

3. Emergency stop method

• When an abnormality is confirmed, stop the machine immediately. When operation is stopped by the RUN/STOP key, turn off the power switch.

Operation Restart Time

Caution

1. Wait five minutes or more before restarting operation after it has been stopped. If the operation is restarted within five minutes, the protection circuit may activate and the operation may not start properly.

Protection Circuit

Caution

1. If operating in the conditions below, the protection circuit will activate and an operation may not be performed or will stop.

- Power supply voltage is not within the rated voltage range of ±10 %.
- In case the water level inside the tank is reduced abnormally.
- Circulating fluid temperature is too high.
- Compared to the cooling capacity, the heat generation amount of the user's equipment is too high.
- Ambient temperature is too high. (40 °C or more)
- Refrigerant pressure is too high.
- Ventilation hole is clogged with dust or dirt.

Maintenance

Caution

<Periodical inspection every one month>

1. Clean the ventilation hole.

If the dustproof filter becomes clogged with dust or debris, a decline in cooling performance can result.

In order to avoid deforming or damaging the dustproof filter, clean it with a long-haired brush or air gun.

<Periodical inspection every three months>

1. Inspect the circulating fluid.

1) When using tap water

- Replacement of tap water

Failure to replace the tap water can lead to the development of bacteria or algae. Replace it regularly depending on your usage conditions.

2) When using ethylene glycol aqueous solution

Use a concentration meter to confirm that the concentration does not exceed 15 %.

Dilute or add as needed to adjust the concentration.

<Periodical inspection during the winter season>

1. Make water-removal arrangements beforehand.

If there is a risk of the circulating fluid freezing when the product is stopped, release the circulating fluid in advance.

2. Consult a professional.

For additional methods to prevent freezing (such as commercially available tape heaters, etc.), consult a professional for advice.

■ Refrigerant with GWP reference

Refrigerant	Global warming potential (GWP)	
	Regulation (EU) No 517/2014 (Based on the IPCC AR4)	Revised Fluorocarbons Recovery and Destruction Law (Japanese law)
R134a	1,430	1,430
R404A	3,922	3,920
R407C	1,774	1,770
R410A	2,088	2,090

- * This product is hermetically sealed and contains fluorinated greenhouse gases (HFC). When this product is sold on the market in the EU after January 1, 2017, it needs to be compliant with the quota system of the F-Gas Regulation in the EU.
- * See specification table for refrigerant used in the product.

Safety Instructions

These safety instructions are intended to prevent hazardous situations and/or equipment damage. These instructions indicate the level of potential hazard with the labels of “Caution,” “Warning” or “Danger.” They are all important notes for safety and must be followed in addition to International Standards (ISO/IEC)*1, and other safety regulations.

 **Caution:** Caution indicates a hazard with a low level of risk which, if not avoided, could result in minor or moderate injury.

 **Warning:** Warning indicates a hazard with a medium level of risk which, if not avoided, could result in death or serious injury.

 **Danger:** Danger indicates a hazard with a high level of risk which, if not avoided, will result in death or serious injury.

Warning

1. The compatibility of the product is the responsibility of the person who designs the equipment or decides its specifications.

Since the product specified here is used under various operating conditions, its compatibility with specific equipment must be decided by the person who designs the equipment or decides its specifications based on necessary analysis and test results. The expected performance and safety assurance of the equipment will be the responsibility of the person who has determined its compatibility with the product. This person should also continuously review all specifications of the product referring to its latest catalogue information, with a view to giving due consideration to any possibility of equipment failure when configuring the equipment.

2. Only personnel with appropriate training should operate machinery and equipment.

The product specified here may become unsafe if handled incorrectly. The assembly, operation and maintenance of machines or equipment including our products must be performed by an operator who is appropriately trained and experienced.

3. Do not service or attempt to remove product and machinery/equipment until safety is confirmed.

1. The inspection and maintenance of machinery/equipment should only be performed after measures to prevent falling or runaway of the driven objects have been confirmed.
2. When the product is to be removed, confirm that the safety measures as mentioned above are implemented and the power from any appropriate source is cut, and read and understand the specific product precautions of all relevant products carefully.
3. Before machinery/equipment is restarted, take measures to prevent unexpected operation and malfunction.

4. Contact SMC beforehand and take special consideration of safety measures if the product is to be used in any of the following conditions.

1. Conditions and environments outside of the given specifications, or use outdoors or in a place exposed to direct sunlight.
2. Installation on equipment in conjunction with atomic energy, railways, air navigation, space, shipping, vehicles, military, medical treatment, combustion and recreation, or equipment in contact with food and beverages, emergency stop circuits, clutch and brake circuits in press applications, safety equipment or other applications unsuitable for the standard specifications described in the product catalogue.
3. An application which could have negative effects on people, property, or animals requiring special safety analysis.
4. Use in an interlock circuit, which requires the provision of double interlock for possible failure by using a mechanical protective function, and periodical checks to confirm proper operation.

- *1) ISO 4414: Pneumatic fluid power – General rules relating to systems.
ISO 4413: Hydraulic fluid power – General rules relating to systems.
IEC 60204-1: Safety of machinery – Electrical equipment of machines.
(Part 1: General requirements)
ISO 10218-1: Manipulating industrial robots - Safety.
etc.

Limited warranty and Disclaimer/ Compliance Requirements

The product used is subject to the following “Limited warranty and Disclaimer” and “Compliance Requirements”.
Read and accept them before using the product.

Limited warranty and Disclaimer

1. The warranty period of the product is 1 year in service or 1.5 years after the product is delivered, whichever is first.*2) Also, the product may have specified durability, running distance or replacement parts. Please consult your nearest sales branch.
2. For any failure or damage reported within the warranty period which is clearly our responsibility, a replacement product or necessary parts will be provided. This limited warranty applies only to our product independently, and not to any other damage incurred due to the failure of the product.
3. Prior to using SMC products, please read and understand the warranty terms and disclaimers noted in the specified catalogue for the particular products.

*2) Vacuum pads are excluded from this 1 year warranty.

A vacuum pad is a consumable part, so it is warranted for a year after it is delivered. Also, even within the warranty period, the wear of a product due to the use of the vacuum pad or failure due to the deterioration of rubber material are not covered by the limited warranty.

Compliance Requirements

1. The use of SMC products with production equipment for the manufacture of weapons of mass destruction (WMD) or any other weapon is strictly prohibited.
2. The exports of SMC products or technology from one country to another are governed by the relevant security laws and regulations of the countries involved in the transaction. Prior to the shipment of a SMC product to another country, assure that all local rules governing that export are known and followed.

Caution

1. The product is provided for use in manufacturing industries.

The product herein described is basically provided for peaceful use in manufacturing industries.

If considering using the product in other industries, consult SMC beforehand and exchange specifications or a contract if necessary.

If anything is unclear, contact your nearest sales branch.

Caution

SMC products are not intended for use as instruments for legal metrology.

Measurement instruments that SMC manufactures or sells have not been qualified by type approval tests relevant to the metrology (measurement) laws of each country. Therefore, SMC products cannot be used for business or certification ordained by the metrology (measurement) laws of each country.

Safety Instructions

Be sure to read “Handling Precautions for SMC Products” (M-E03-3) before using.

SMC Corporation (Europe)

Austria	+43 (0)2262622800	www.smc.at	office@smc.at	Lithuania	+370 5 2308118	www.smc.lt	info@smc.lt
Belgium	+32 (0)33551464	www.smc.be	info@smc.be	Netherlands	+31 (0)205318888	www.smc.nl	info@smc.nl
Bulgaria	+359 (0)2807670	www.smc.bg	office@smc.bg	Norway	+47 67129020	www.smc-norge.no	post@smc-norge.no
Croatia	+385 (0)13707288	www.smc.hr	office@smc.hr	Poland	+48 222119600	www.smc.pl	office@smc.pl
Czech Republic	+420 541424611	www.smc.cz	office@smc.cz	Portugal	+351 226166570	www.smc.si	postpt@smc.smces.es
Denmark	+45 70252900	www.smc.dk.com	smc@smcdk.com	Romania	+40 213205111	www.smcromania.ro	smcromania@smcromania.ro
Estonia	+372 6510370	www.smc.ee	smc@smcpneumatics.ee	Russia	+7 8127185445	www.smc-pneumatik.ru	info@smc-pneumatik.ru
Finland	+358 207513513	www.smc.fi	smc@smc.fi	Slovakia	+421 (0)413213212	www.smc.sk	office@smc.sk
France	+33 (0)164761000	www.smc-france.fr	info@smc-france.fr	Slovenia	+386 (0)73885412	www.smc.si	office@smc.si
Germany	+49 (0)61034020	www.smc.de	info@smc.de	Spain	+34 945184100	www.smc.es	post@smc.smces.es
Greece	+30 210 2717265	www.smc-hellas.gr	sales@smc-hellas.gr	Sweden	+46 (0)86031200	www.smc.nu	post@smc.nu
Hungary	+36 23513000	www.smc.hu	office@smc.hu	Switzerland	+41 (0)523963131	www.smc.ch	info@smc.ch
Ireland	+353 (0)14039000	www.smc-pneumatics.ie	sales@smc-pneumatics.ie	Turkey	+90 212 489 0 440	www.smc-pneumatik.com.tr	info@smc-pneumatik.com.tr
Italy	+39 0292711	www.smc-italia.it	mailbox@smc-italia.it	UK	+44 (0)845 121 5122	www.smc.uk	sales@smc.uk
Latvia	+371 67817700	www.smc.lv	info@smc.lv				

SMC CORPORATION Akihabara UDX 15F, 4-14-1, Sotokanda, Chiyoda-ku, Tokyo 101-0021, JAPAN Phone: 03-5207-8249 FAX: 03-5298-5362

1st printing XO printing XO 00 Printed in Spain

Specifications are subject to change without prior notice and any obligation on the part of the manufacturer.