

Peltier-Type Temperature Control System for Chemicals

Chemical Thermo-con

Fluororesin heat exchanger allows direct temperature control for chemicals!!

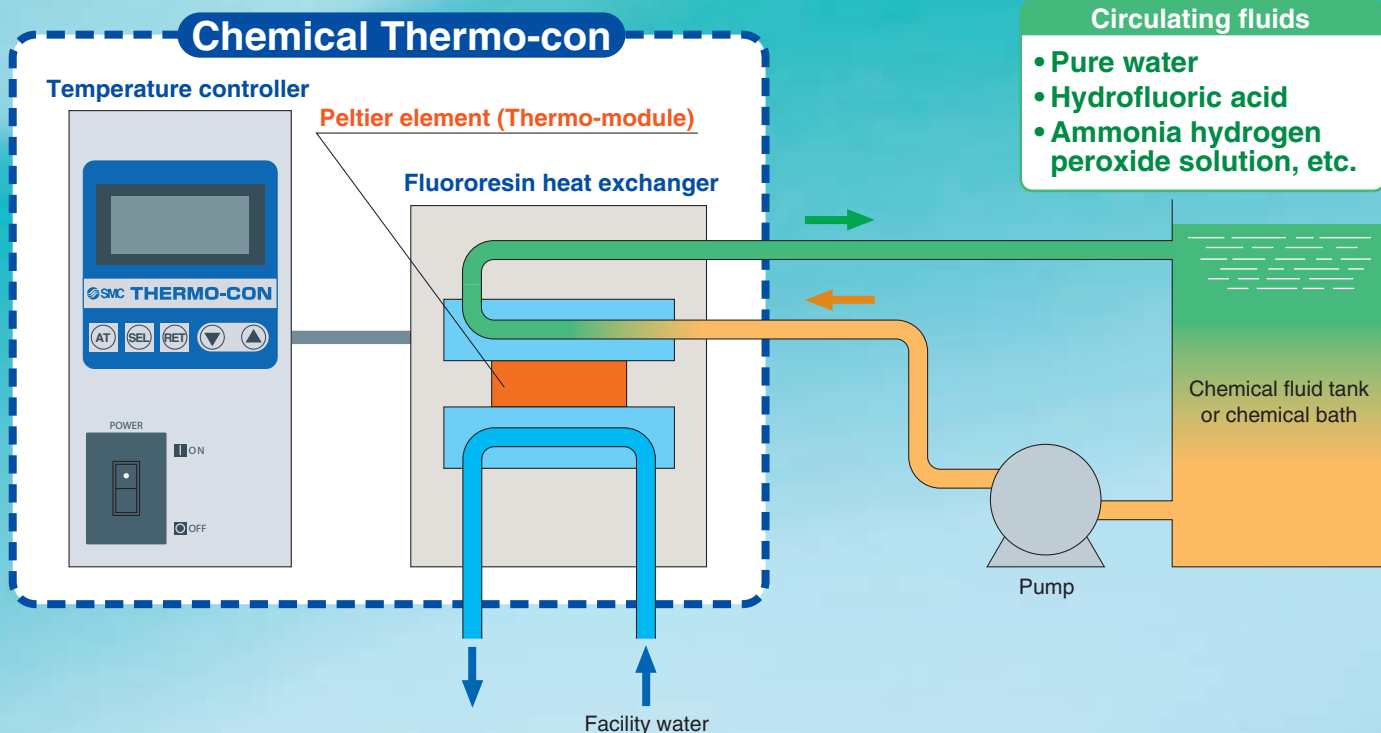

Industry-leading withstand pressure

0.35 MPa (50 PSI)!!

• Operating temp. range: **10°C to 60°C**

• Temperature stability: **0.1°C**

• Cooling capacity (with water):

300 w, 500 w, 750 w

• Safety standards:

CE, UL, (eti[®])
NRTL compliant

• **RoHS** compliant

Series **HED**



SMC

CAT.EUS40-54A-UK

Allows direct control of chemical temperature.

- PFA wetted material prevents contamination from metal ion elution.
- No need of a tube-type heat exchanger.

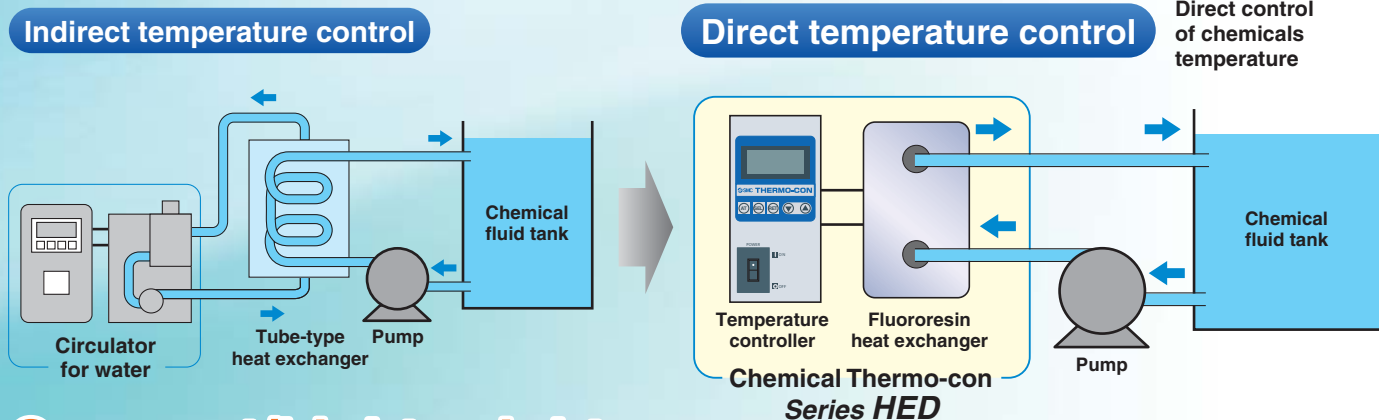

Compact/Lightweight

- Self-developed heat exchanger matched to the configuration of the Peltier element (Thermo-module). Compact and light weight

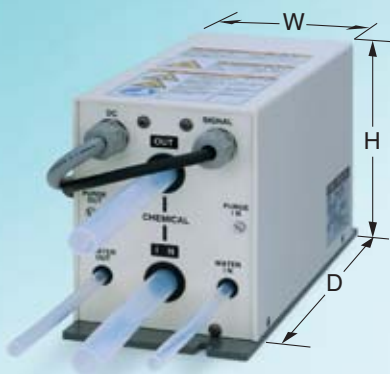

Heat Exchanger

Model	W	D	H	Weight
HED003	130 mm (5.12")	263 mm (10.4")	170 mm (6.69")	8 kg (17.6 lb)
HED005	150 mm (5.91")	294 mm (11.6")	222 mm (8.74")	14 kg (30.8 lb)
HED007				15 kg (33 lb)

Note) The outline dimensions do not include protruding parts such as foot flange and tube.

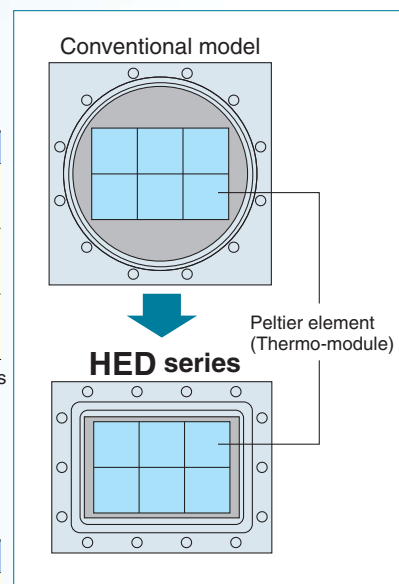

Temperature Controller

Model	W	D	H	Weight
HED003	100 mm (3.94")	320 mm (12.6")	215 mm (8.46")	6 kg (13.2 lb)
HED005	140 mm (5.51")	350 mm (13.8")	215 mm (8.46")	8 kg (17.6 lb)
HED007	165 mm (6.50")	447 mm (17.6")	215 mm (8.46")	13 kg (28.6 lb)

Note) The outline dimensions do not include protruding parts such as foot flange and tube.

● Applications

For Semiconductor industry

Cleaning equipment

Plating equipment

Wet etching equipment, etc.

And for any other industry ...

● Applicable Fluid Example

Chemical	Operating temperature range	Chemical	Operating temperature range
Pure water	10 to 60°C	Ammonia hydrogen peroxide solution	10 to 60°C
Hydrofluoric acid	10 to 40°C	Sodium hydroxide	10 to 60°C
Sulfuric acid (except fuming sulfuric acid)	10 to 50°C	Ozone water	10 to 60°C
Copper sulfate solution	10 to 50°C		

Note) Chemical Thermo-con is not designed explosion proof, so it is not suitable for flammable fluids.

Principle of Peltier Element (Thermo-module/thermoelectric device)

The Peltier element is a plate-shape solid state element with P type and N type semiconductor, arrayed alternately. When direct current is supplied to the element, heat moves from one surface to another with electron flow in N type semiconductor and electron hole in P type semiconductor. As a result of the movement heat, one surface of the element absorbs heat and decreases temperature; and other surface heats up. When the DC current is switched to reverse direction, the heat movement will also be in reverse direction. Therefore, Peltier element can achieve heating effect as well as cooling effect depending on the current direction. It can achieve high speed switching and precise temperature control.

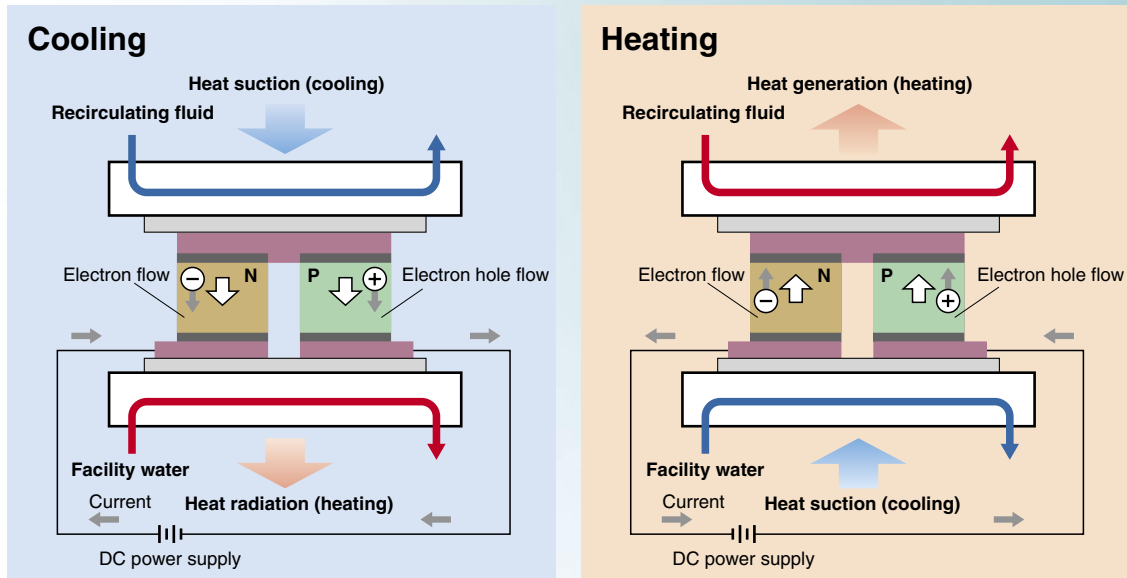

System Construction and Principle

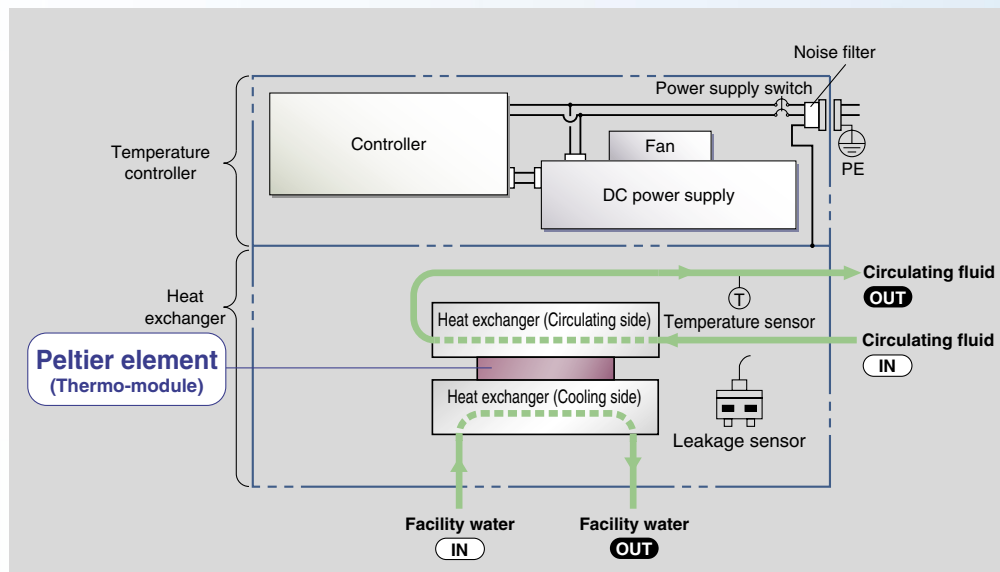

The temperature controller consists of CPU and DC power supply to energise the Peltier elements and outputs appropriate DC power to the peltier elements based on a differential between set point and a value of temperature sensor. The temperature sensor is installed in the heat exchanger, and the leakage sensor is installed in the heat exchanger to detect unexpected water or chemical leakage..

Series HED Model Selection

Model Selection Guide

Example 1: In cases where the amount of heat generated in the customer's equipment is known.

Heat generation source Q: 400 W (at 25°C)

Cooling capacity = Considering a safety factor of 20%, select $400 \text{ W} \times 1.2 = \boxed{480 \text{ W (at 25°C)}}$ or more.

Example 2: In cases where the amount of heat generated in the customer's equipment is not known.

Obtaining the temperature difference between inlet and outlet by circulating the circulating fluid inside the customer's equipment.

Heat generation amount Q	: Unknown
Circulating fluid temperature difference ($\Delta T (= T_2 - T_1)$)	: 1.0°C (1.0 K)
Circulating fluid outlet temperature (T1)	: 20°C (293.15 K)
Circulating fluid inlet temperature (T2)	: 21°C (294.15 K)
Circulating fluid flow rate (L)	: 7 ℓ/min
Circulating fluid	: Water
	Density γ : $1 \times 10^3 \text{ kg/m}^3$
	Specific heat C: $4.2 \times 10^3 \text{ J/(kg}\cdot\text{K)}$

$$Q = \frac{\Delta T \times L \times \gamma \times C}{60 \times 1000}$$

$$= \frac{1 \times 7 \times 1 \times 10^3 \times 4.2 \times 10^3}{60 \times 1000}$$

$$= 490 \text{ W}$$

Cooling capacity = Considering a safety factor of 20%,
 $490 \times 1.2 = \boxed{588 \text{ W}}$

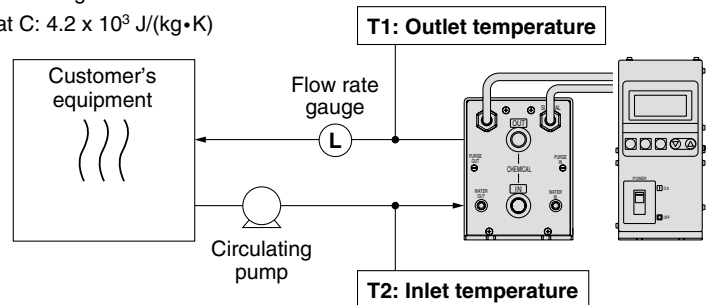

Example 3: In cases where cooling the object below a certain temperature and period of time.

Total volume of the object being cooled down (V)	: 20 ℓ
Cooling time (h)	: 15 min
Cooling temperature difference (ΔT)	: 5°C (5 K)
Circulating fluid	: Water
	Density γ : $1 \times 10^3 \text{ kg/m}^3$
	Specific heat C: $4.2 \times 10^3 \text{ J/(kg}\cdot\text{K)}$

$$Q = \frac{\Delta T \times V \times \gamma \times C}{h \times 60 \times 1000}$$

$$= \frac{5 \times 20 \times 1 \times 10^3 \times 4.2 \times 10^3}{15 \times 60 \times 1000}$$

$$= 467 \text{ W}$$

Cooling capacity = Considering a safety factor of 20%,
 $467 \times 1.2 = \boxed{560 \text{ W}}$

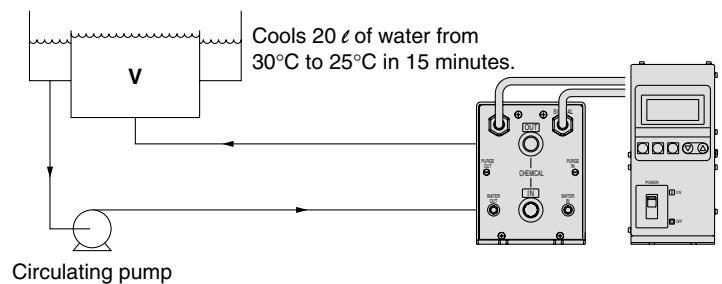

Model Selection Precautions

The flow rate of the circulating fluid depends on the internal resistance of the customer's equipment and the length, diameter and resistance created by bends in the circulating fluid piping, etc. Check if the required flow rate of circulating fluid can be obtained before using.

Chemical Thermo-con Series *HED*

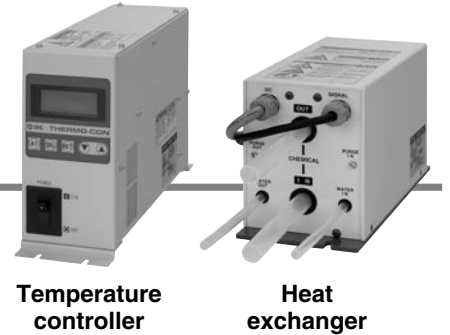

How to Order

Set Part number (Temperature controller + Heat exchanger)

Note) The name plate on the Chemical Thermo-con shows the model numbers of the temperature controller and the heat exchanger.

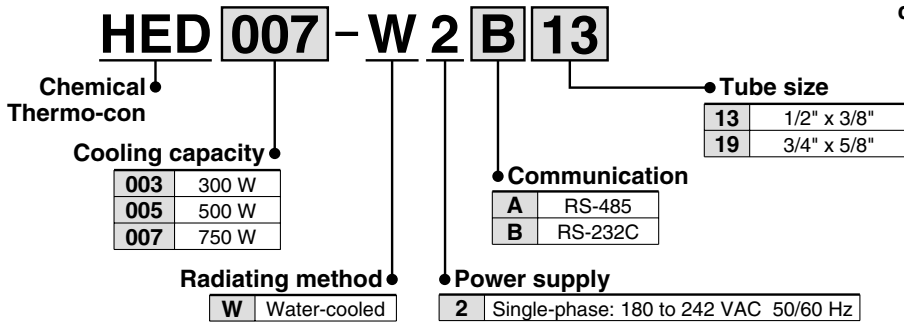

Combination in Set

Part number of set	Heat exchanger model	Temperature controller model
HED003-W2A13	HED003-HW13	HED003-C2A
HED003-W2A19	HED003-HW19	
HED003-W2B13	HED003-HW13	HED003-C2B
HED003-W2B19	HED003-HW19	
HED005-W2A13	HED005-HW13	HED005-C2A
HED005-W2A19	HED005-HW19	
HED005-W2B13	HED005-HW13	HED005-C2B
HED005-W2B19	HED005-HW19	
HED007-W2A13	HED007-HW13	HED007-C2A
HED007-W2A19	HED007-HW19	
HED007-W2B13	HED007-HW13	HED007-C2B
HED007-W2B19	HED007-HW19	

Heat exchanger

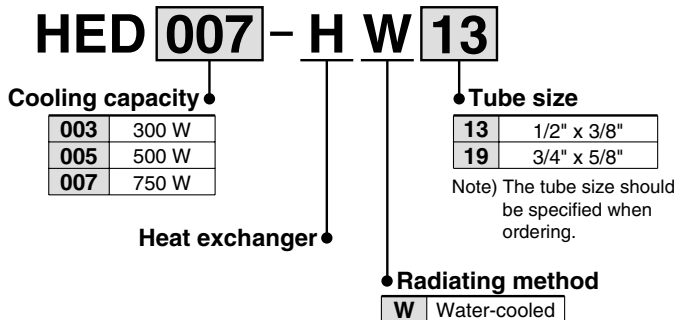

Temperature controller

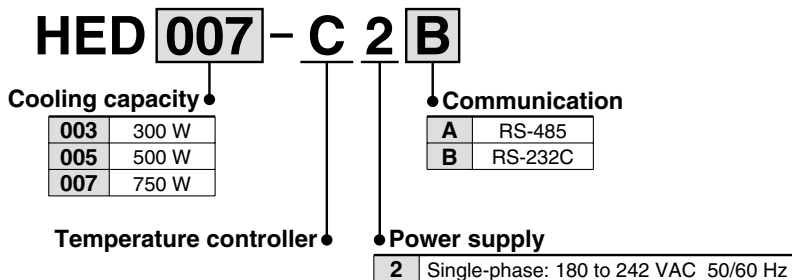

Main Specifications (For details, please consult our "Product Specifications" information.)

Heat Exchanger Specifications

Heat exchanger model		HED003-HW13	HED003-HW19	HED005-HW13	HED005-HW19	HED007-HW13	HED007-HW19
Cooling capacity (Water) <small>Note 1)</small>		300 W		500 W		750 W	
Heating capacity (Water) <small>Note 1)</small>		600 W		1000 W		1800 W	
Cooling/Heating method		Peltier element (Thermoelectric device, Thermo-module)					
Radiating method		Water-cooled					
Operating temperature range		10.0 to 60.0°C (depending on the type of circulating fluid)					
Circulating fluid	Applicable fluid <small>Note 2)</small>	Pure water, Hydrofluoric acid, Ammonia hydrogen peroxide solution, etc.					
	Wetted material	PFA					
	Operating pressure <small>Note 3)</small>	0 (atmospheric pressure) to 0.35 MPa (0 to 50.75 PSI)					
	Tube size (PFA tube)	1/2" x 3/8"	3/4" x 5/8"	1/2" x 3/8"	3/4" x 5/8"	1/2" x 3/8"	3/4" x 5/8"
Facility water	Temperature	10 to 35°C (no condensation)					
	Wetted material	FEP, Stainless steel 304, Stainless steel 316					
	Max. operating pressure	0.5 MPa (72.5 PSI)					
	Tube size	IN/OUT: FEP tube 3/8" x 1/4"					
	Flow rate	5 to 10 l/min (1.3 to 2.6 g/m)					
Ambient		Temperature: 10 to 35°C, Humidity: 35 to 80%RH (no condensation)					
Dimensions <small>Note 4)</small>		W130 mm x D263 mm x H170 mm (W5.12" x D10.4" x H6.69")		W150 mm x D294 mm x H222 mm (W5.91" x D11.6" x H8.74")		W150 mm x D294 mm x H222 mm (W5.91" x D11.6" x H8.74")	
Weight		Approx. 8 kg (17.6 lb)		Approx. 14 kg (30.8 lb)		Approx. 15 kg (33 lb)	
Applied temperature controller		HED003-C2A HED003-C2B		HED005-C2A HED005-C2B		HED007-C2A HED007-C2B	

Note 1) The conditions are as follows.

Circulating fluid: Water (Circulating flow rate 15 l/min, Set temperature 25°C); Facility water temperature: 25°C; Facility water flow rate: 5 l/min; Ambient temperature: 25°C

Note 2) For the compatibility between the circulating fluid and materials, refer to "Applicable Fluids" (page 8).

Note that the Chemical Thermo-con is not designed explosion proof so it is not suitable for flammable fluids.

Note 3) Install the heat exchanger in the discharge side of a circulating pump. Do not use at location where a negative pressure is applied.

The circulating fluid pump should be prepared by the customer.

Note 4) The outline dimensions do not included protruding parts such as foot flange and tube.

Temperature Controller Specifications

Temperature controller model		HED003-C2A	HED003-C2B	HED005-C2A	HED005-C2B	HED007-C2A	HED007-C2B
Communication		RS-485	RS-232C	RS-485	RS-232C	RS-485	RS-232C
Control method		Cooling/Heating automatic shift PID control					
Operating temp. range		10.0 to 60.0°C (no condensation)					
Temperature stability <small>Note 1)</small>		Within ±0.1°C (with stable load)					
Temperature sensor		Resistance thermometer Pt100 Ω, 3-wires, class A, 2 mA (for both internal control sensor and external sensor) <small>Note 4)</small>					
Main functions		Auto-tuning, Sensor fine adjustment, Offset, Learning control, External sensor control, Set value memory, Upper/lower temperature limit alarm, Output shutdown alarm, Remote ON/OFF, Leakage detection					
Ambient		Temperature: 10 to 35°C, Humidity: 35 to 80%RH (no condensation)					
Power supply spec.	Power supply	Single-phase: 180 to 242 VAC 50/60 Hz					
	Rated current	3A		5A		14A	
Dimensions <small>Note 2)</small>		W100 mm x D320 mm x H215 mm (W3.94" x D12.6" x H8.46")		W140 mm x D350 mm x H215 mm (W5.51" x D13.8" x H8.46")		W165 mm x D447 mm x H215 mm (W6.50" x D17.6" x H8.46")	
Mass		Approx. 6 kg (13.2 lb)		Approx. 8 kg (17.6 lb)		Approx. 13 kg (28.6 lb)	
Applied heat exchanger <small>Note 3)</small>		HED003-HW13 HED003-HW19		HED005-HW13 HED005-HW19		HED007-HW13 HED007-HW19	

Note 1) This value is for a stable load with no disturbance and cannot be achieved in determined operating conditions.

Note 2) The outline dimensions do not included protruding parts such as the foot flange, screw and connector.

Note 3) The temperature controller should be connected with a specific series of heat exchanger. If connected with a different series of heat exchanger, it may not operate normally. (The HED003 and HED005 series use the same connector, so be careful for incorrect wiring.)

Note 4) The external sensor should be prepared by the customer.

⚠ Caution

• For the combination of a heat exchanger with a temperature controller, refer to "Combination in Set".

Series HED

The values shown on the performance chart are representative and not guaranteed. Allow a safety margin when choosing the product.

Cooling Capacity <Conditions> Circulating fluid: Water; Circulating fluid flow rate: 15 l/min; Facility water flow rate: 5 l/min

HED003

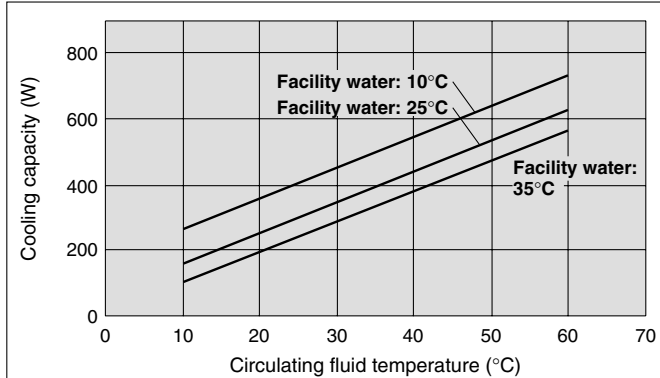

HED005

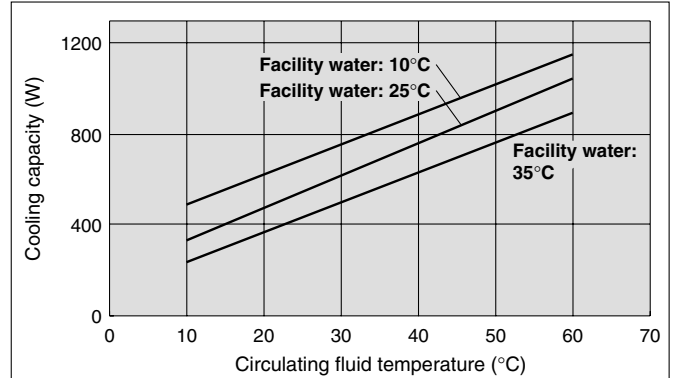

HED007

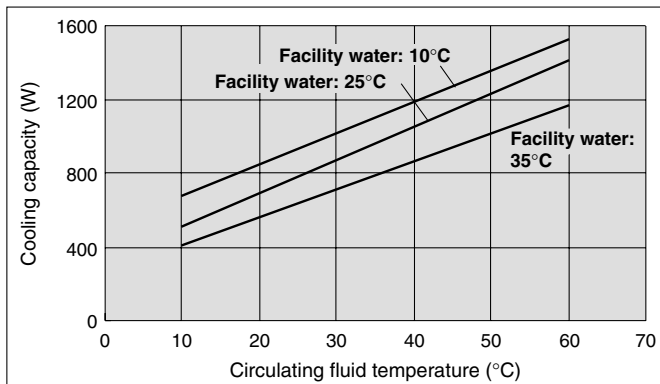

Heating Capacity <Conditions> Circulating fluid: Water; Circulating fluid flow rate: 15 l/min; Facility water flow rate: 5 l/min

HED003

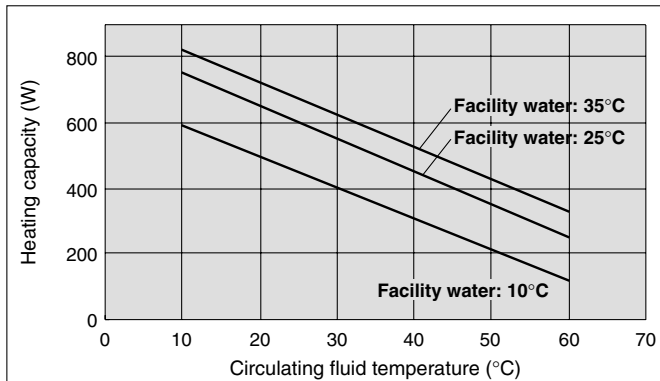

HED005

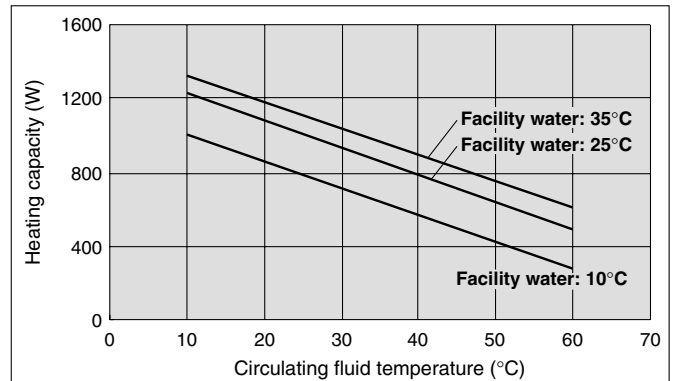

HED007

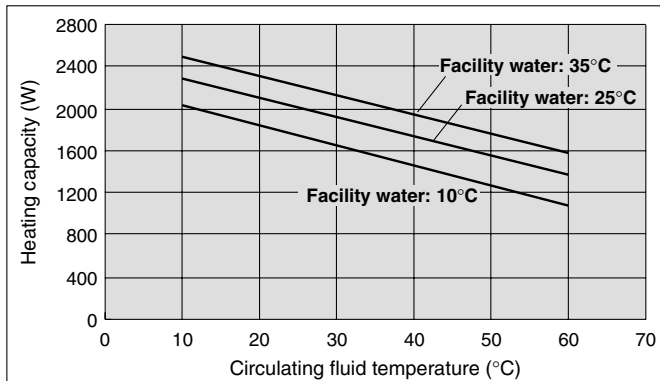

Pressure Loss in Circulating Fluid Circuit <Condition> Water

HED003

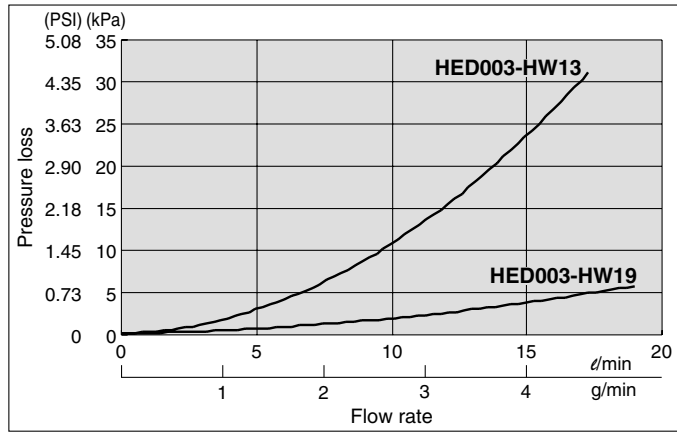

**HED005
HED007**

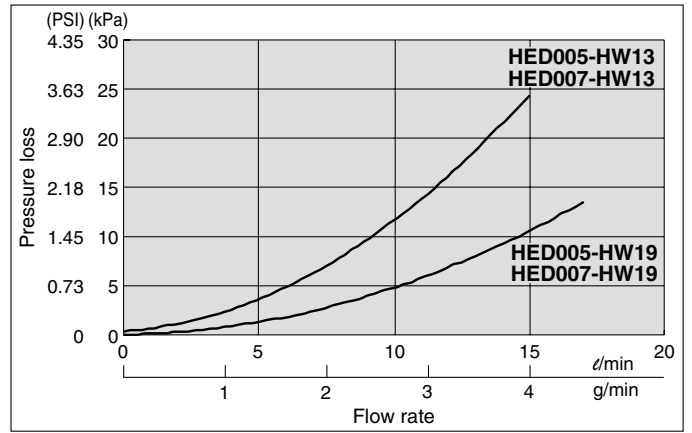

Pressure Loss in Facility Water Circuit <Condition> Water

HED003

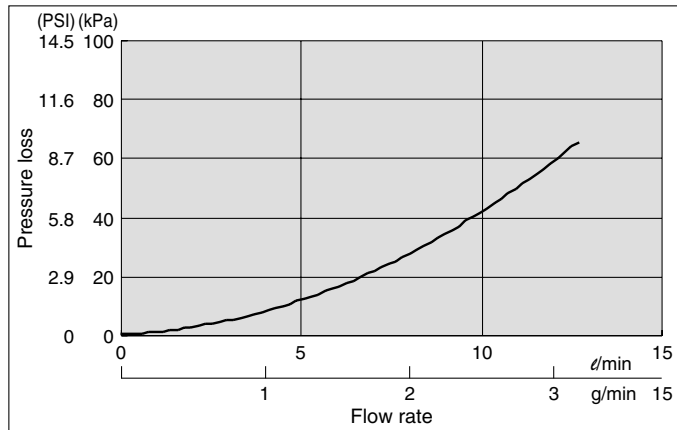

**HED005
HED007**

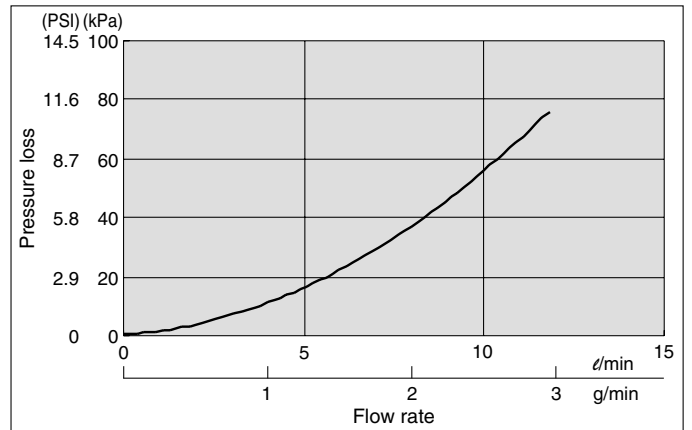

Series HED

Dimensions

HED003-W2□□

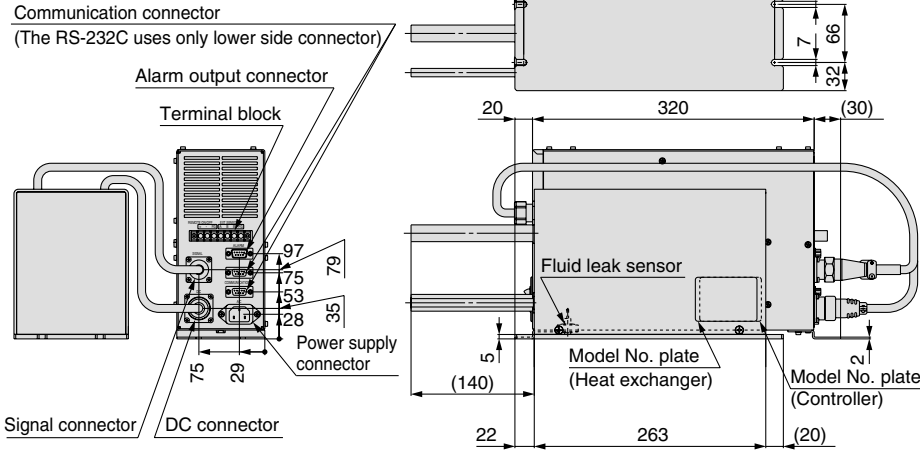

Temperature controller Heat exchanger HED003-C2□ HED003-HW□

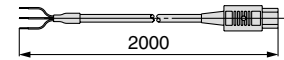
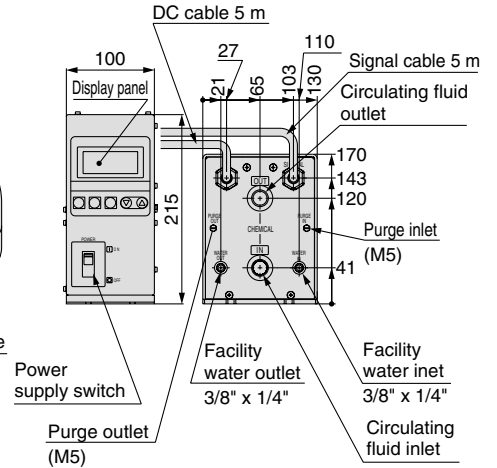

Power Supply Cable (Accessory)

Connector: IEC60320 C13 or equivalent
Cable: 14AWG, O.D. ø8.4

Wire colour	Content
Black 1	180 to 242 VAC
Black 2	180 to 242 VAC
Green/Yellow	PE

Circulating Fluid Tube Size

Heat exchanger model	Circulating fluid tube size
HED003-HW13	1/2" x 3/8"
HED003-HW19	3/4" x 5/8"

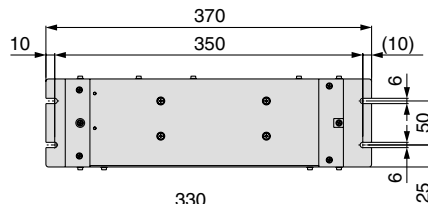

HED005-W2□□

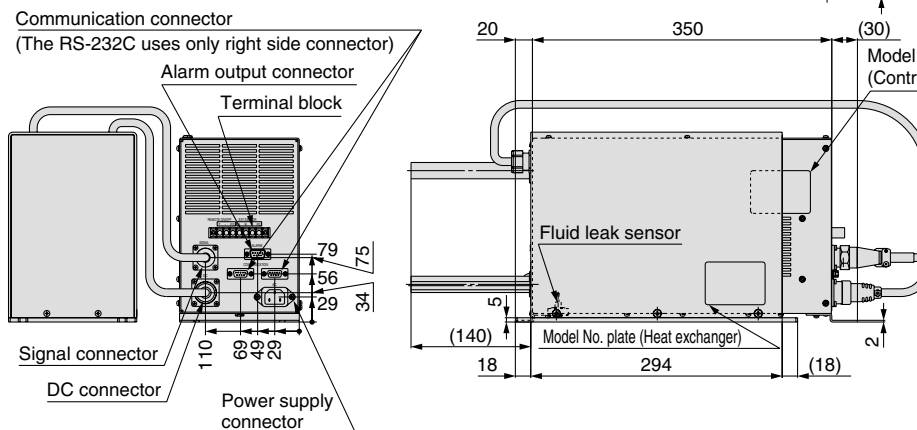

Temperature controller Heat exchanger HED005-C2□ HED005-HW□

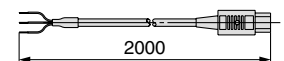
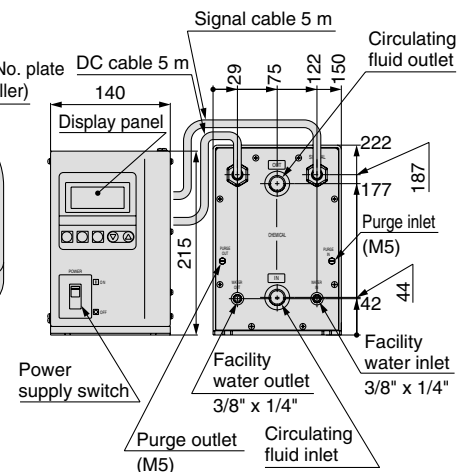

Power Supply Cable (Accessory)

Connector: IEC60320 C13 or equivalent
Cable: 14AWG, O.D. ø8.4

Wire colour	Content
Black 1	180 to 242 VAC
Black 2	180 to 242 VAC
Green/Yellow	PE

Circulating Fluid Tube Size

Heat exchanger model	Circulating fluid tube size
HED005-HW13	1/2" x 3/8"
HED005-HW19	3/4" x 5/8"

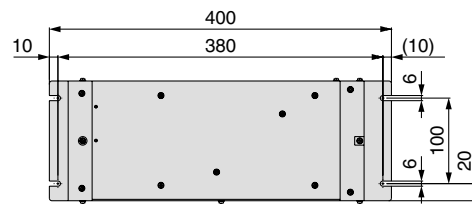

Dimensions

HED007-W2□□

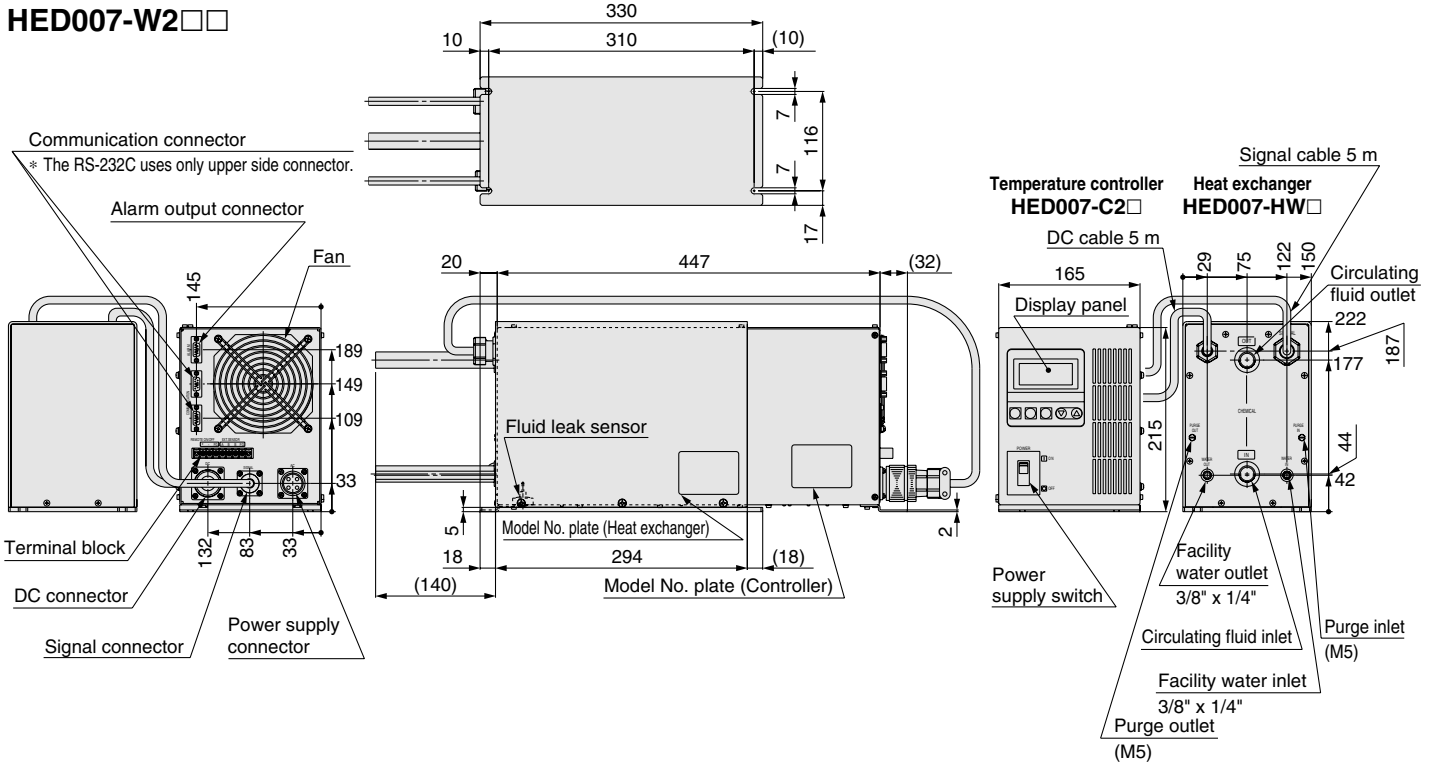

Circulating Fluid Tube Size

Heat exchanger model	Circulating fluid tube size
HED007-HW13	1/2" x 3/8"
HED007-HW19	3/4" x 5/8"

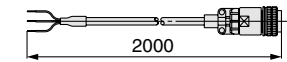

Power Supply Cable (Accessory)

Connector: DDK CE05-6A18-10SD-D-BSS
Cable: 12AWG, O.D. ϕ 11.8

Wire colour	Content
Black 1	180 to 242 VAC
Black 2	180 to 242 VAC
Green/Yellow	PE

Alarm

The Chemical Thermo-con has failure diagnosis function. When an failure happens, its failure mode is displayed in the LCD display on the controller and it can be read out through the serial communication. And the Chemical Thermo-con has relay outputs for upper/lower temperature limit alarm and shutdown alarm.

Alarm no.	Alarm description	Operation condition	Main reason
WRN	Upper/lower temp. limit alarm	Continue	The temperature has exceeded the upper or lower limit of the set temperature.
WRN	Remote OFF alarm	Stop	The remote ON/OFF contact is set to be off. (This alarm is not generated by the relay output.)
ERR00	CPU hung-up	Stop	The CPU has crashed due to noise, etc.
ERR01	CPU check failure	Stop	The contents of the CPU cannot be read out correctly when the power supply is turned on.
ERR03	Back-up data error	Stop	The contents of the back-up data cannot be read out correctly when the power supply is turned on.
ERR04	EEPROM writing error	Stop	The data cannot be written to EEPROM.
ERR05	EEPROM input over time error	Stop	The number of times of writing to EEPROM has exceeded the maximum value.
ERR11	DC power voltage failure	Stop	Momentary loss of AC power supply, DC power supply has excessive temperature, or the thermo-module has been short-circuited.
ERR12	Internal sensor value is high.	Stop	The internal temperature sensor has exceeded the upper limit where the Chemical Thermo-con is set to stop.
ERR13	Internal sensor value is low.	Stop	The internal temperature sensor has exceeded the lower limit where the Chemical Thermo-con is set to stop.
ERR14	Thermostat alarm	Stop	The thermostat has been activated due to insufficient flow rate of the circulating fluid or facility water or high temperature.
ERR15	Output failure alarm	Continue	The temperature cannot be changed even at 100% output, due to overload or disconnection of the thermo-module.
ERR17	Cutoff/short of internal sensor	Stop	The internal temperature sensor has been disconnected or short-circuited.
ERR18	Cutoff/short of external sensor	Continued by normal control	The external temperature sensor has been disconnected or short-circuited. (Only detected when in learning control, auto-tuning operation 2, or external sensor control)
ERR19	Auto-tuning failure	Stop	Auto-tuning has not been completed within 60 minutes.
ERR21	Fan alarm	Stop	The air-cooled fan alarm of the power supply has been activated.
ERR22	Leak alarm	Stop	The fluid leak sensor has detected leakage of fluid.

Maintenance

Please prepare back-up equipment as necessary to minimize the downtime.

1) Heat exchanger

The heat exchanger can only be repaired during warranty by returning it to SMC for investigation. The unit has to be completely decontaminated with an appropriate method (such as the use of neutralizing agent) before returning it to SMC.

2) Temperature controller

The temperature controller maintenance is only performed at SMC's site. On the other hand, following parts have a limited life and need to be replaced before th life ends.

Parts Life Expectation

Description	Expected life	Possible failure
Fan	5 to 10 years	Lack of fan cooling because of the bearing life time. It will activate the overheat protection of DC power supply and generate an alarm.
DC power supply	5 to 10 years	End life of electrolytic condenser. It will generate DC power supply alarm.
Display panel	50,000 hours (approx. 5 years)	End life of LCD display backlight.



Applicable Fluids

Chemical Compatibility Table against the Wetted Material in Chemical Thermo-con

Chemical	Operating temperature range	Compatibility
Hydrofluoric acid	10 to 40°C	○ Note 2)
Buffered hydrogen fluoride	10 to 40°C	○ Note 2)
Hydrofluoric acid and nitric acid mixture		△
Nitric acid (except fuming nitric acid)		△
Hydrochloric acid		△
Copper sulfate solution	10 to 50°C Note) HED007 10 to 30°C	○ Note 2)
Sulfuric acid (except fuming sulfuric acid)	10 to 50°C Note) HED007 10 to 30°C	○ Note 2)
Ozone	10 to 60°C	◎
Ammonium hydroxide	10 to 60°C	○ Note 2)
Ammonia hydrogen peroxide solution	10 to 60°C	○ Note 1) 2)
Sodium hydroxide	10 to 60°C	○ Note 2)
Pure water	10 to 60°C	○ Note 1)
Ultra pure water	10 to 60°C	○ Note 1)

◎ : Excellent No effect
○ : Good Minor effect/Conditional service
△ : Fair Moderate effect → Consult SMC.



The table should be used only as a general guide. SMC is not responsible for the accuracy of this data and assumes no obligation of liability in connection with its use. Therefore, SMC insists all customers to test and evaluate the suitability for the Chemical Thermo-con use in its particular application before using it.

Note 1) Static electricity may be generated by dynamic function with the fluid, causing a malfunction of electric components. In these cases, it's necessary to consider some measures, such as the use of conductive PFA tube or the use of metal piping with ground wire.

Note 2) Permeation of the chemical may be possible. The permeated chemical may have a moderate corrosion to inside components and it may effect their life time. In case the fluid has a possibility to generate corrosive gas, SMC recommends a nitrogen purge of the enclosure. N2 purge ports are located at the piping connection side of the heat exchanger.





Safety Instructions

These safety instructions are intended to prevent a hazardous situations and/or equipment damage. These instructions indicate the level of potential hazard by the labels of “**Caution,**” “**Warning**” or “**Danger.**” To ensure safety, be sure to observe ISO/IEC and JIS B standards ^{Note 1)} and other safety practices ^{Note 2)}.

Note 1) ISO 4414: Pneumatic fluid power – General rules relating to systems.
ISO 4413: Hydraulic fluid power – General rules relating to systems.
IEC 60204-1: Safety of machinery – Electrical equipment of machines. (Part 1: General requirements)
ISO 10218-1992: Manipulating industrial robots -Safety.
JIS B 8370: General rules for pneumatic equipment.
JIS B 8361: General rules for hydraulic equipment.
JIS B 9960-1: Safety of machinery – Electrical equipment of machines. (Part 1: General requirements)
JIS B 8433-1993: Manipulating industrial robots - Safety.
etc.

Note 2) Labour Safety, Sanitation Law, etc.

 **Caution:** Operator error could result in injury or equipment damage.

 **Warning:** Operator error could result in serious injury or loss of life.

 **Danger :** In extreme conditions, there is a possibility of serious injury or loss of life.

Warning

1. The compatibility of the equipment is responsibility of the person who designs the system or decides its specifications.

Since the product specified here is used under various operating conditions, its compatibility for specific system must be decided by the person who designs the equipment or decides its specifications based on necessary analysis and test results. The expected performance and safety are responsibility of the person who has determined its compatibility of the system. This person should also continuously review the suitability of all items specified referring to the latest catalog information with a view to giving due consideration to any possibility of equipment failure when configuring the system.

2. Only trained personnel should operate pneumatic/hydraulic operated machinery and equipment.

Compressed air can be dangerous if handled incorrectly. Assembly, handling or repair of the system using pneumatic/hydraulic equipment should be performed by trained and experienced operators (understanding JIS B 8370 and 8361, and other safety rules are included).

3. Do not service machinery/equipment or attempt to remove components until safety is confirmed.

1. Inspection and maintenance of machinery/equipment should only be performed after measures to prevent falling or runaway of the driven objects have been confirmed.

2. When the equipment is removed, confirm the safety process as mentioned above. Turn off the source and read and understand carefully the specific precautions for all relevant equipment.

3. Before machinery/equipment is restarted, take measures to prevent unexpected operation and malfunction.

4. Contact SMC if the product is to be used in any of the following conditions:

1. Conditions and environments beyond the given specifications, or if product is used outdoors.

2. Installation on equipment in conjunction with atomic energy, railway, air navigation, space, shipping, vehicles, military, medical treatment, combustion and recreation, or equipment in contact with food and beverages, emergency stop circuits, clutch and brake circuits in press applications, safety equipment or any other applications unsuitable for the specifications described in the catalogue.

3. An application which was the possibility of having negative effects on people, property, or animals requiring special safety analysis.

4. If the equipment is used in an interlock circuit, prepare a double interlock style circuit with a mechanical protection function for the prevention of breakdown. Also examine the devices periodically to check if they function normally or not.



Temperature Control Equipment Precautions 1

Be sure to read this before handling. Refer to back pages 1 and 2 for Safety Instructions and back pages 5 to 7 for Specific Product Precautions.

Selection

Warning

1. Confirm the specifications.

Fully understand the applications, environment, fluids and other operating conditions, and use this product within the specified range shown in this catalogue. Other wise it can cause injury, damage, or malfunction. When in doubt, contact SMC.

2. Secure the performance margin.

Due to heat losses from the piping and pressure drops, consider an allowance when calculating cooling/heating capacity or flow characteristics of the product.

Operating Environment / Storage Environment

Warning

1. Observe the operating ambient temperature range.

The operating ambient temperature must be within the specification range shown in this catalogue.

Using beyond the range will lead to damage, breakage or malfunction.

2. Avoid using and storing in the following environment to prevent malfunctions:

1. In locations where water, steam, brine, and oil may splash directly on the product.
2. In locations where a large amount of particles are airborne.
3. In locations with a corrosive atmosphere or with explosive gases, solvents, or chemicals.
(This product is not explosion proof.)
4. In locations which receive direct sunlight or radiated heat.
(Protect from direct sunshine to avoid the resin from deteriorating by ultraviolet rays or increasing the temperature.)
5. In locations where temperature substantially changes.
6. In locations where there is a heat source nearby and the ventilation is poor.
(Insulate the heat source or ventilate in a proper way to avoid damages caused by a temperature increase, such as softening.)
7. In locations where condensation occurs.
8. In locations where strong magnetic noise occurs (locations with strong electric fields, strong magnetic fields and surge voltage).
9. In locations where static electricity occurs, or conditions which make the product discharge static electricity.
10. In locations where high frequency occurs.
11. In locations where damage is likely to occur due to lightning.
12. In locations where impacts or vibrations occur.
13. In conditions where a massive force strong enough to deform the product is applied or a weight from a heavy object is applied.
14. In locations more than 1000 m in altitude (except for storage or transportation).

Fluid

Warning

1. Type of fluids

1. The operating fluids must be used within the specified range shown in this catalogue.
Consult SMC when using the product with other fluids.
2. Install a filter if the fluid is being mixed with other matter.

Transportation / Transfer / Movement

Warning

1. Product transport should be performed by an experienced person.

As this product is heavy, use caution to prevent falling down or dropping accidents.

2. Avoid transporting in following environments:

1. In conditions with strong shock and vibrations.
2. In operating and storage environments other than those specified.

3. Caution when transporting a heavy object

Use caution to avoid injury when picking up and setting down the product, and to avoid falling and dropping accidents.

4. Before moving this product, remove operating fluid, and facility water from the inside of this product.

Mounting / Installation

Warning

1. Installation should be performed by an experienced person.

At this product is heavy, use caution to avoid falling and dropping accidents.

Caution

1. Provide enough space for ventilation and maintenance.

Provide enough space for ventilation of every equipment, otherwise a cooling malfunction or operation stoppage may occur. Also, provide space required for maintenance.

2. Confirm the mounting orientation.

Mount and install horizontally.



Temperature Control Equipment Precautions 2

Be sure to read this before handling. Refer to back pages 1 and 2 for Safety Instructions and back pages 5 to 7 for Specific Product Precautions.

Operation

Warning

- 1. Handle and operate after the safety of this product and the whole system are confirmed.**
Operate this product by a knowledgeable and experienced person.
- 2. Before operation, confirm the safety of mounting, installation, piping and electric wiring conditions.**
 1. Confirm that the mounting and installation conditions are safe.
 2. Confirm that the circulating fluid is filled and that the fluid level is within the display range.
 3. Confirm whether the valve is open or closed and that the hose and resin tube are not twisted.
It is dangerous when the valve in the piping is closed because the circulating fluid and the facility water will not flow and the fluid pressure will increase.
 4. Confirm the fluid flow direction.
Make sure that the flow direction of the fluid (Inlet/Outlet direction) is connected correctly.
 5. Confirm that the electrical wiring condition is safe.
Incorrect wiring will lead to a malfunction or breakage of the product. Confirm that there is no wiring errors before operation.
 6. When using the product with a 3-phase power supply, confirm the connection.
If the phase order is incorrect, either the pump, will run in reverse, or the phase-reversal relay will activate and the product will not operate.
In this case, after cutting off the main power supply, reverse 2 wires out of the 3 wires and connect them in the correct phase order.
- 3. Do not remove the external panel during energization or operation.**
If removed, there are the dangers of electrical shock, burn, frostbite, injury from a rotating object.
- 4. Avoid operating with a lower flow.**
Avoid operating with a lower flow due to the temperature control may become unstable or the service life of the pump may shorten.
- 5. Confirm the safety during the operation.**
If an emergency is detected, stop the operation product immediately and cut the power supply breaker.
- 6. When not used for a long period of time, confirm the safety before beginning again its operation.**

Maintenance

Warning

- 1. Maintenance should be performed according to the procedure indicated in the operating manual.**
Improper handling can cause damage and malfunction of equipment and machinery.
- 2. Maintenance operations**
Improper handling of compressed air is dangerous. Therefore, replacement of elements and other maintenance activities should be performed by trained and experienced personnel.
- 3. Pre-maintenance inspection**
When removing this product, turn off the electric power, and be sure certain to shut off the supply pressure and exhaust the compressed air in the system. Proceed only after confirming that all pressure has been released to the atmosphere.
- 4. Post maintenance inspection**
After installation or repair, reconnect compressed air and electricity and confirm proper operation by inspection. If there is an audible air leakage, or if the equipment does not operate properly, stop operation and confirm that the equipment is correctly installed.
- 5. Modification prohibited**
Do not modify or reconstruct the unit.
- 6. Stopping for long periods of time**
When not using for long periods of time, remove the operating fluid (circulating fluid, facility water) and cut the main power supply.
- 7. Removal of product**
Take the stop/inspection measures and confirm that there is no danger before the product is removed.
If removing the product, discharge the used fluid and clean the inside of the piping. If a dangerous fluid or polluted fluid is left, the polluted area can be enlarged or an accident can occur.
- 8. Disposal of product**
When the product is disposed, it must be in compliance with the local ordinances.
Please ask a professional industrial waste disposal company for help.
In case of a refrigerated type product, entrust a company to collect the Freon®. Then, the customer may be requested to submit a certificate that is showing the type of operating fluid and whether any quantity is left.
These procedures are responsibility of the customer.
- 9. Preparation of a backup product**
In order to minimize the downtime prepare a backup product.



Series HED Specific Product Precautions 1

Be sure to read this before handling. Refer to back pages 1 and 2 for Safety Instructions and back pages 3 and 4 for Temperature Control Equipment Precautions.

System Design

⚠ Warning

This catalogue shows the specifications of the Chemical Thermo-con.

1. Check detailed specifications in the separate “Product Specifications”, and evaluate the compatibility of the Chemical Thermo-con with the customer’s system.
2. The Chemical Thermo-con is equipped with a protective circuit independently, but the whole system should be designed by the customer to ensure safety.

Handling

⚠ Warning

1. Read the operating manual.

Read the operating manual completely before operation, and keep this manual available whenever necessary.

Operating Environment / Storage Environment

⚠ Warning

1. Keep within the specified ambient temperature and humidity range. If the set temperature is too low, condensation may form on the inside of the Chemical Thermo-con or the surface of piping even within the specified ambient temperature range. Dew condensation can cause failure, so avoid it by considering operating conditions.
2. The Chemical Thermo-con is not designed for clean room usage: the fan generates dust.
3. Low molecular siloxane can damage the contact of the relay. Use the Chemical Thermo-con in a place free from low molecular siloxane.

Piping

⚠ Warning

1. Piping must be designed considering the whole system.

Design of the piping system should be performed by a knowledgeable and experienced person.

As the fitting is not attached, it should be prepared separately by the customer.

Select a fitting suitable for the material and dimensions of the tube. When connecting the fitting, use a specific tool as specified by the fitting manufacturer.

Piping

⚠ Warning

2. Work performed on the piping should be done by a knowledgeable and experienced person.
3. Confirm the leakage of fluid.
Fluid leakage can cause dangerous accidents. Be sure that the hose or tubing is not pulled out and that there is no leakage in the fitted parts.
4. Confirm that the resin tube is not kinked or collapsed.
If a resin tube is used, for kinks or collapses.
5. Countermeasures against fluid leakage

Water drops may accumulate due to leakage of circulating fluid or facility water, or condensation on the piping. Install the Chemical Thermo-con with a drip pan, fluid leak sensor and exhaust system.

If leakage is detected, cut off both the circulating pump with a hardware interlock, and the power to the Chemical Thermo-con.

Depending on the type of chemical used (circulating fluid), it may have a harmful effect on the surrounding equipment and the human body.

⚠ Caution

1. Before piping

Confirm that dust, scales etc., in contact with piping are cleaned up or air blown (flushing) before piping.

2. Take care over the direction of fluid.

Check the direction “IN” and “OUT” directions for the facility water system and circulating fluid system.

3. Take countermeasures against condensation.

Take countermeasures such as installing insulation material, to avoid condensations.

4. Avoid electrostatic discharge.

If a fluid with low conductivity such as pure water is used as the circulating fluid, static electricity generated by flow friction may be discharged to the temperature sensor and malfunction the Chemical Thermo-con. Consider measures to minimize the discharge of static electricity from the circulating fluid to signal line including the temperature sensor.

For example, a PFA conductive tube or metal piping (metal flexible hose) can be used to provide grounding to the piping of the external sensor and to discharge.



Series HED Specific Product Precautions 2

Be sure to read this before handling. Refer to back pages 1 and 2 for Safety Instructions and back pages 3 and 4 for Temperature Control Equipment Precautions.

Electrical Wiring

⚠ Warning

1. Electrical wiring should be performed by a knowledgeable and experienced person.

Power supply facilities and wiring works should be implemented in accordance with the electric facilities technical standards and provisions and conducted correctly.

2. Mounting a dedicated circuit breaker.

As a countermeasure against current leakage, install a ground fault circuit interrupter (GFCI) in the main power supply.

3. Confirmation of power supply

If this product is used with voltages other than specified, it will likely lead to a fire or an electrical shock. Before wiring, confirm the voltage, capacity, and frequency, and that the voltage fluctuation is within the specified value.

4. Grounding

Be sure to ground (frame ground) with class D grounding (grounding resistance of 100 Ω or less): it can be grounded with the PE line of the power supply cable.

Also, do not use together with equipment that generates a strong electrical magnetic noise or high frequency noise.

5. Wiring cable should be handled with care.

Do not bend, twist or pull the cord or cable.

6. Use an adequate cable size and terminal.

In the event of attaching a power supply cable, use a cable and terminal size which are suitable for the electrical current of each product.

Forcibly mounting with an unsuitable size cable will likely result in a fire.

7. Avoid wiring the signal line and power line in parallel.

Since there may be a possibility of malfunction from noise, avoid parallel wiring between the temperature sensor line, communications line, signal line of alarm line, etc. and the power line and high voltage line. Also, do not place them in the same wiring tube.

8. Check for incorrect wiring.

Incorrect wiring can damage the Chemical Thermo-con or cause malfunction.

9. Check the model of the Chemical Thermo-con.

The HED003 and HED005 series use the same connector. If the temperature controller and heat exchanger of different models are combined by mistake, an alarm may be generated and the specified performance may not be obtained. Be sure to check the combination of models.

Facility Water Supply

⚠ Warning

1. Be sure to supply the facility water.

1. Prohibition of water-cut operation, very little flow rate of water operation:

Do not operate when there is no facility water or there is very little flow rate of water flowing. (Facility water flow rate range: 5 to 10 ℓ/min)

In this kind of operation, facility water temperature may become extremely higher. It is dangerous enough the material of hose may soften and burst when the piping supplying the facility water is connected with hose.

2. Actions to be taken when an emergency stop occurs due to extremely high temperature:

In case a stop occurs due to extremely high temperature resulting from a decrease in the facility water flow rate, do not immediately flow facility water. First, naturally let it cool down, removing the cause of the flow rate reduction. Secondly, make sure that there is no leakage again.

⚠ Caution

1. Facility water quality

1. Use the facility water within the specified range.

When using with other fluid than facility water, consult SMC.

2. Install a filter (20 mesh or equivalent) if any foreign matter can enter the fluid.

Facility Water Quality Standards

The Japan Refrigeration and Air Conditioning Industry Association
JRA GL-02-1994 "Cooling water system – Circulating type – Circulating water"

	Item	Standard value
Standard item	pH (at 25°C)	6.5 to 8.2
	Electrical conductivity (25°C)	100 ^{Note)} to 800 [μS/cm]
	Chloride ion	200 [mg/L] or less
	Sulfuric acid ion	200 [mg/L] or less
	Acid consumption amount (at pH4.8)	100 [mg/L] or less
	Total hardness	200 [mg/L] or less
	Calcium hardness	150 [mg/L] or less
Reference item	Ionic state silica	50 [mg/L] or less
	Iron	1.0 [mg/L] or less
	Copper	0.3 [mg/L] or less
	Sulfide ion	Should not be detected.
	Ammonium ion	1.0 [mg/L] or less
	Residual chlorine	0.3 [mg/L] or less
	Free carbon	4.0 [mg/L] or less

Note) Electrical conductivity should be 100 [μS/cm] or more.

2. If the temperature of the facility water is too low, it can cause condensation inside the heat exchanger.

Supply facility water with a temperature over the atmospheric dew point to avoid the formation of dew condensation.

3. If the facility water piping is connected to multiple machines, the facility water exchanges heat at the upstream side and its temperature will become higher as it goes downstream.

Limit the number of connected Chemical Thermo-cons to two per facility water system. If more chemical thermo-cons are to be connected, increase the number of systems.



Series HED Specific Product Precautions 3

Be sure to read this before handling. Refer to back pages 1 and 2 for Safety Instructions and back pages 3 and 4 for Temperature Control Equipment Precautions.

Installation

⚠ Caution

1. Mount and install horizontally.

When mounting, fix the foot of the Chemical Thermo-con by tightening the screws to the specified torque below.

Recommended Mounting Torque

Device to mount	Thread size	Applicable tightening torque N·m
Heat exchanger	M6	1.5 to 2.5
Temperature controller	M5	1.5 to 2.5

Circulating Fluid

⚠ Caution

1. Applicable fluids

Refer to “Applicable Fluids” (page 8), and contact SMC for fluids other than those described on the check list.

2. Caution for the use of fluids with high permeation

When the Chemical Thermo-con is used for a fluid with high permeation into fluorine resin, the permeation can affect its life. If the fluid also generates corrosive gas, perform N₂ supply and exhaust (N₂ purge) inside the heat exchanger.

3. Caution when using of pure water

If pure water is used, bacteria and algae may grow in a short period. If the Chemical Thermo-con is operated with bacteria and algae, the performance of the heat exchanger may deteriorate. Exchange all pure water regularly depending on the conditions (once a month as a guide).

4. Small flow rate

Be sure to avoid operation with the circulating pump stopped or with extremely small flow rate of recirculating fluid (7 ℓ/min or less for water). Otherwise, the Chemical Thermo-con will repeat change cooling and heating operation, which may shorten the life of the Peltier element significantly, and it will become unable to control the temperature accurately. When the circulating pump is stopped, stop the temperature control of the Chemical Thermo-con by also using the remote ON/OFF function.

5. Operating pressure range of circulating fluid

The operating pressure range is 0 to 0.35 MPa. Do not use with negative pressure that can cause the Chemical Thermo-con to fail (install the heat exchanger at the secondary (discharge) side of the circulating pump.) Also, avoid excessive pressure being applied to the circulating fluid circuit by a clogged filter or fully closed valve.

6. Fluid pulsation prohibition

If a pump generating pulsation is used, install a damper to absorb the pulsation directly before the Chemical Thermo-con. Fluid pulsation can break the Chemical Thermo-con.

Communication

⚠ Caution

1. The set value can be written to EEPROM, but only up to about 1 million times.

Pay attention to the number of times the writing is performed using the communication function.

Maintenance

⚠ Warning

1. Prevention of electric shock and fire

Do not operate the switch with wet hands. Also, do not operate the Chemical Thermo-con with water or fluid left on it.

2. Action in case of error

If any error such as abnormal noise, smoke, or bad smell occurs, cut off the power, stop supplying facility water and contact SMC or a sales distributor to repair the Chemical Thermo-con.

3. Regular inspection

Check the following items at least once a month, by an operator who has sufficient knowledge and experience:

- Displayed contents.
- Temperature, vibration and abnormal sounds in the body of the Chemical Thermo-con.
- Voltage and current of the power supply system.
- Leakage and contamination of the circulating fluid and intrusion of foreign matter to it, and subsequent replacement water.
- Leakage, quality change, flow rate and temperature of facility water.

4. Protective clothing

Some fluids can be dangerous when handled incorrectly so wear protective clothing for safety during maintenance. In particular, observe the MSDS of the circulating fluid, and wear protective goggles, gloves and mask for the operation of the Chemical Thermo-con.



Goggles



Mask



Gloves



Safety shoes

EUROPEAN SUBSIDIARIES:

Austria

SMC Pneumatik GmbH (Austria).
Girakstrasse 8, A-2100 Korneuburg
Phone: +43 2262-622800, Fax: +43 2262-62285
E-mail: office@smc.at
http://www.smc.at

France

SMC Pneumatique, S.A.
1, Boulevard de Strasbourg, Parc Gustave Eiffel
Bussy Saint Georges F-77607 Marne La Vallée Cedex 3
Phone: +33 (0)1-6476 1000, Fax: +33 (0)1-6476 1010
E-mail: contact@smc-france.fr
http://www.smc-france.fr

Netherlands

SMC Pneumatics BV
De Ruyterkade 120, NL-1011 AB Amsterdam
Phone: +31 (0)20-5318888, Fax: +31 (0)20-5318880
E-mail: info@smcpneumatics.nl
http://www.smcpneumatics.nl

Spain

SMC España, S.A.
Zuazobidea 14, 01015 Vitoria
Phone: +34 945-184 100, Fax: +34 945-184 124
E-mail: post@smc.smces.es
http://www.smc.eu

Belgium

SMC Pneumatics N.V./S.A.
Nijverheidsstraat 20, B-2160 Wommelgem
Phone: +32 (0)3-355-1464, Fax: +32 (0)3-355-1466
E-mail: info@smcpneumatics.be
http://www.smcpneumatics.be

Germany

SMC Pneumatik GmbH
Boschring 13-15, D-63329 Egelsbach
Phone: +49 (0)6103-4020, Fax: +49 (0)6103-402139
E-mail: info@smc-pneumatik.de
http://www.smc-pneumatik.de

Norway

SMC Pneumatics Norway A/S
Vollsveien 13 C, Granfos Næringspark N-1366 Lysaker
Tel: +47 67 12 90 20, Fax: +47 67 12 90 21
E-mail: post@smc-norge.no
http://www.smc-norge.no

Sweden

SMC Pneumatics Sweden AB
Ekhagsvägen 29-31, S-141 71 Huddinge
Phone: +46 (0)8-603 12 00, Fax: +46 (0)8-603 12 90
E-mail: post@smcpneumatics.se
http://www.smc.nu

Bulgaria

SMC Industrial Automation Bulgaria EOOD
Business Park Sofia, Building 8 - 6th floor, BG-1715 Sofia
Phone: +359 2 9744492, Fax: +359 2 9744519
E-mail: office@smc.bg
http://www.smc.bg

Greece

SMC Hellas EPE
Anagenniseos 7-9 - P.C. 14342, N. Philadelphia, Athens
Phone: +30-210-2717265, Fax: +30-210-2717766
E-mail: sales@smchellas.gr
http://www.smchellas.gr

Poland

SMC Industrial Automation Polska Sp.z.o.o.
ul. Poloneza 89, PL-02-826 Warszawa
Phone: +48 22 211 9600, Fax: +48 22 211 9617
E-mail: office@smc.pl
http://www.smc.pl

Switzerland

SMC Pneumatik AG
Dorfstrasse 7, CH-8484 Weisslingen
Phone: +41 (0)52-396-3131, Fax: +41 (0)52-396-3191
E-mail: info@smc.ch
http://www.smc.ch

Croatia

SMC Industrijska automatika d.o.o.
Crnomerec 12, HR-10000 ZAGREB
Phone: +385 1 377 66 74, Fax: +385 1 377 66 74
E-mail: office@smc.hr
http://www.smc.hr

Hungary

SMC Hungary Ipari Automatizálási Kft.
Torbágy út 19, H-2045 Törökbálint
Phone: +36 23 511 390, Fax: +36 23 511 391
E-mail: office@smc.hu
http://www.smc.hu

Portugal

SMC Sucursal Portugal, S.A.
Rua de Eng^o Ferreira Dias 452, 4100-246 Porto
Phone: +351 226 166 570, Fax: +351 226 166 589
E-mail: postpt@smc.smces.es
http://www.smc.eu

Turkey

Entek Pnömatik San. ve Tic. A*.
Perpa Ticaret Merkezi B Blok Kat:11 No: 1625, TR-34386, Okmeydanı, Istanbul
Phone: +90 (0)212-444-0762, Fax: +90 (0)212-221-1519
E-mail: smc@entek.com.tr
http://www.entek.com.tr

Czech Republic

SMC Industrial Automation CZ s.r.o.
Hudcova 78a, CZ-61200 Brno
Phone: +420 5 414 24611, Fax: +420 5 412 18034
E-mail: office@smc.cz
http://www.smc.cz

Ireland

SMC Pneumatics (Ireland) Ltd.
2002 Citywest Business Campus, Naas Road, Saggart, Co. Dublin
Phone: +353 (0)1-403 9000, Fax: +353 (0)1-464-0500
E-mail: sales@smcpneumatics.ie
http://www.smcpneumatics.ie

Romania

SMC Romania srl
Str Frunzei 29, Sector 2, Bucharest
Phone: +40 213205111, Fax: +40 213261489
E-mail: smcromania@smcromania.ro
http://www.smcromania.ro

UK

SMC Pneumatics (UK) Ltd
Vincent Avenue, Crownhill, Milton Keynes, MK8 0AN
Phone: +44 (0)800 1382930 Fax: +44 (0)1908-555064
E-mail: sales@smcpneumatics.co.uk
http://www.smcpneumatics.co.uk

Denmark

SMC Pneumatik A/S
Egeskovvej 1, DK-8700 Horsens
Phone: +45 70252900, Fax: +45 70252901
E-mail: smc@smcdk.com
http://www.smcdk.com

Italy

SMC Italia S.p.A
Via Garibaldi 62, I-20061 Carugate, (Milano)
Phone: +39 (0)2-92711, Fax: +39 (0)2-9271365
E-mail: mailbox@smcitalia.it
http://www.smcitalia.it

Russia

SMC Pneumatik LLC.
4B Sverdlovskaja nab, St. Petersburg 195009
Phone: +7 812 718 5445, Fax: +7 812 718 5449
E-mail: info@smc-pneumatik.ru
http://www.smc-pneumatik.ru

Estonia

SMC Pneumatics Estonia OÜ
Laki 12, 106 21 Tallinn
Phone: +372 6510370, Fax: +372 65110371
E-mail: smc@smcpneumatics.ee
http://www.smcpneumatics.ee

Latvia

SMC Pneumatics Latvia SIA
Smerla 1-705, Riga LV-1006
Phone: +371 781-77-00, Fax: +371 781-77-01
E-mail: info@smclv.lv
http://www.smclv.lv

Slovakia

SMC Priemyselná Automatizácia, s.r.o.
Fatranská 1223, 01301 Teplicka Nad Váhom
Phone: +421 41 3213212 - 6 Fax: +421 41 3213210
E-mail: office@smc.sk
http://www.smc.sk

Finland

SMC Pneumatics Finland Oy
PL72, Tiistinniityntie 4, SF-02231 ESPOO
Phone: +358 207 513513, Fax: +358 207 513595
E-mail: smcfin@smc.fi
http://www.smc.fi

Lithuania

SMC Pneumatics Lietuva, UAB
Oslo g.1, LT-04123 Vilnius
Phone: +370 5 264 81 26, Fax: +370 5 264 81 26

Slovenia

SMC industrijska Avtomatika d.o.o.
Mirska cesta 7, SI-8210 Trebnje
Phone: +386 7 3885412 Fax: +386 7 3885435
E-mail: office@smc.si
http://www.smc.si

OTHER SUBSIDIARIES WORLDWIDE:

ARGENTINA, AUSTRALIA, BOLIVIA, BRASIL, CANADA, CHILE,
CHINA, HONG KONG, INDIA, INDONESIA, MALAYSIA, MEXICO,
NEW ZEALAND, PHILIPPINES, SINGAPORE, SOUTH KOREA,
TAIWAN, THAILAND, USA, VENEZUELA

<http://www.smc.eu>
<http://www.smcworld.com>